

JENN-AIR® BOTTOM MOUNT BUILT-IN REFRIGERATOR

REFRIGERADOR EMPOTRADO CON
CONGELADOR EN LA PARTE INFERIOR JENN-AIR®

RÉFRIGÉRATEUR ENCASTRÉ AVEC
CONGÉLATEUR EN BAS JENN-AIR®

USE & CARE GUIDE

For questions about features, operation/performance, parts, accessories, or service,
call **1-800-JENNAIR (1-800-536-6247)** or visit our website at **www.jennair.com**.

In Canada, call **1-800-JENNAIR (1-800-536-6247)** or visit our website at **www.jennair.ca**.

MANUAL DE USO Y CUIDADO

Si tiene preguntas respecto a las características, funcionamiento, rendimiento, partes, accesorios o servicio técnico,
llame al **1-800-JENNAIR (1-800-536-6247)** o visite nuestro sitio de internet: **www.jennair.com**.

En Canadá, llame al **1-800-JENNAIR (1-800-536-6247)** o visite nuestro sitio de internet: **www.jennair.ca**.

GUIDE D'UTILISATION ET D'ENTRETIEN

Au Canada, pour assistance, installation ou service, composez le **1-800-JENNAIR (1-800-536-6247)**
ou visitez notre site Web à **www.jennair.ca**.

Table of Contents / Índice / Table des matières2

JENN-AIR®

W10728796A

TABLE OF CONTENTS

REFRIGERATOR SAFETY	3	DOOR FEATURES	10
Proper Disposal of Your Old Refrigerator.....	4	Utility Compartment.....	10
BEFORE USE	4	Door Bins.....	10
Water Supply Requirements.....	4	REFRIGERATOR CARE	11
Water System Preparation.....	5	Cleaning.....	11
Install Air Filter.....	5	Lights.....	11
Install Produce Preserver.....	5	Power Interruptions.....	11
REFRIGERATOR USE	6	Vacation Care.....	12
Power On/Off Switch.....	6	TROUBLESHOOTING	12
Using the Controls.....	6	Refrigerator Operation.....	12
Ice Maker and Storage Bin.....	8	Temperature and Moisture.....	13
Water Filtration System.....	8	Ice and Water.....	13
REFRIGERATOR FEATURES	9	ASSISTANCE OR SERVICE	14
Refrigerator Shelves.....	9	In the U.S.A.....	14
Deli/Crisper Drawers.....	10	In Canada.....	14
Wine Rack.....	10	ACCESSORIES	14
FREEZER FEATURES	10	WATER FILTER CERTIFICATIONS	15
Freezer Drawer and Pull-out Ice Bin.....	10	PERFORMANCE DATA SHEETS	16
		WARRANTY	18

ÍNDICE

SEGURIDAD DEL REFRIGERADOR	19	CARACTERÍSTICAS DE LA PUERTA	28
Cómo deshacerse adecuadamente de su refrigerador viejo.....	20	Compartimiento de uso general.....	28
ANTES DE USAR	20	Recipientes de la puerta.....	28
Requisitos del suministro de agua.....	20	CUIDADO DE SU REFRIGERADOR	28
Preparación del sistema de agua.....	21	Limpieza.....	28
Instalación del filtro de aire.....	21	Luces.....	29
Instalación del preservador de alimentos frescos.....	21	Cortes de corriente.....	29
USO DE SU REFRIGERADOR	22	Cuidado durante las vacaciones.....	29
Interruptor de On/Off (Encendido/Apagado).....	22	SOLUCIÓN DE PROBLEMAS	30
Uso de los controles.....	23	Funcionamiento del refrigerador.....	30
Fábrica de hielo y depósito.....	25	Temperatura y humedad.....	31
Sistema de filtración de agua.....	25	Hielo y agua.....	31
CARACTERÍSTICAS DEL REFRIGERADOR	26	AYUDA O SERVICIO TÉCNICO	32
Estantes del refrigerador.....	26	En los EE.UU.....	32
Cajón para carnes frías y cajón para verduras.....	27	En Canadá.....	32
Portabotellas.....	27	ACCESORIOS	32
CARACTERÍSTICAS DEL CONGELADOR	27	HOJA DE DATOS DEL RENDIMIENTO	33
Cajón del congelador y depósito removible de hielo.....	27	GARANTÍA	35

TABLE DES MATIÈRES

SÉCURITÉ DU RÉFRIGÉRATEUR	37	CARACTÉRISTIQUES DE LA PORTE	46
Mise au rebut de votre vieux réfrigérateur.....	38	Compartiment utilitaire.....	46
AVANT L'UTILISATION	38	Balconnets de porte.....	46
Spécifications de l'alimentation en eau.....	38	ENTRETIEN DU RÉFRIGÉRATEUR	46
Préparation du système d'eau.....	39	Nettoyage.....	46
Installation du filtre à air.....	39	Lampes.....	47
Installation du conservateur pour produits frais.....	39	Pannes de courant.....	47
UTILISATION DU RÉFRIGÉRATEUR	40	Entretien avant les vacances.....	47
Interrupteur d'alimentation On/Off (marche/arrêt).....	40	DÉPANNAGE	48
Utilisation des commandes.....	41	Fonctionnement du réfrigérateur.....	48
Machine à glaçons et bac d'entreposage.....	43	Température et humidité.....	49
Système de filtration d'eau.....	43	Glaçons et eau.....	49
CARACTÉRISTIQUES DU RÉFRIGÉRATEUR	44	ASSISTANCE OU SERVICE	50
Tablettes du réfrigérateur.....	44	ACCESSOIRES	50
Bacs pour spécialités alimentaires/bacs à légumes.....	45	FEUILLES DE DONNÉES SUR LA PERFORMANCE	51
Casier à vin.....	45	GARANTIE	53
CARACTÉRISTIQUES DU CONGÉLATEUR	45		
Bac de congélateur et bac à glaçons coulissant.....	45		

REFRIGERATOR SAFETY

Your safety and the safety of others are very important.

We have provided many important safety messages in this manual and on your appliance. Always read and obey all safety messages.



This is the safety alert symbol.

This symbol alerts you to potential hazards that can kill or hurt you and others.

All safety messages will follow the safety alert symbol and either the word "DANGER" or "WARNING."

These words mean:

⚠ DANGER

You can be killed or seriously injured if you don't immediately follow instructions.

⚠ WARNING

You can be killed or seriously injured if you don't follow instructions.

All safety messages will tell you what the potential hazard is, tell you how to reduce the chance of injury, and tell you what can happen if the instructions are not followed.

IMPORTANT SAFETY INSTRUCTIONS

WARNING: To reduce the risk of fire, electric shock, or injury when using your refrigerator, follow these basic precautions:

- Plug into a grounded 3 prong outlet.
- Do not remove ground prong.
- Do not use an adapter.
- Do not use an extension cord.
- Disconnect power before servicing.
- Replace all parts and panels before operating.
- Remove doors from your old refrigerator.
- Use nonflammable cleaner.
- Keep flammable materials and vapors, such as gasoline, away from refrigerator.
- Use two or more people to move and install refrigerator.
- Disconnect power before installing ice maker (on ice maker kit ready models only).
- Use a sturdy glass when dispensing ice (on some models).
- Do not hit the refrigerator glass doors (on some models).

SAVE THESE INSTRUCTIONS

State of California Proposition 65 Warnings:

WARNING: This product contains one or more chemicals known to the State of California to cause cancer.

WARNING: This product contains one or more chemicals known to the State of California to cause birth defects or other reproductive harm.

Proper Disposal of Your Old Refrigerator

⚠️ WARNING

Suffocation Hazard

Remove doors from your old refrigerator.

Failure to do so can result in death or brain damage.

IMPORTANT: Child entrapment and suffocation are not problems of the past. Junked or abandoned refrigerators are still dangerous – even if they will sit for “just a few days.” If you are getting rid of your old refrigerator, please follow these instructions to help prevent accidents.

Before You Throw Away Your Old Refrigerator or Freezer:

- Take off the doors.
- Leave the shelves in place so that children may not easily climb inside.

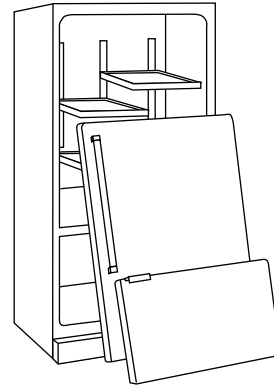

Important information to know about disposal of refrigerants:

Dispose of refrigerator in accordance with Federal and Local regulations. Refrigerants must be evacuated by a licensed, EPA certified refrigerant technician in accordance with established procedures.

BEFORE USE

Remove the Packaging

- Remove tape and glue residue from surfaces before turning on the refrigerator. Rub a small amount of liquid dish soap over the adhesive with your fingers. Wipe with warm water and dry.
- Do not use sharp instruments, rubbing alcohol, flammable fluids, or abrasive cleaners to remove tape or glue. These products can damage the surface of your refrigerator. For more information, see “Refrigerator Safety.”
- Dispose of/recycle all packaging materials.

Clean Before Using

After you remove all of the packaging materials, clean the inside of your refrigerator before using it. See the cleaning instructions in “Refrigerator Care.”

Important information to know about glass shelves and covers:

Do not clean glass shelves or covers with warm water when they are cold. Shelves and covers may break if exposed to sudden temperature changes or impact, such as bumping. Tempered glass is designed to shatter into many small, pebble-size pieces. This is normal. Glass shelves and covers are heavy. Use both hands when removing them to avoid dropping.

Water Supply Requirements

Read all directions before you begin.

IMPORTANT:

- When your refrigerator was installed, the water connection from the water source should have been connected to your refrigerator. If your refrigerator is not connected to a water source, see “Connect to Water Line” in the Installation Instructions. If you have any questions about your water connection, see “Troubleshooting” or call a licensed, qualified plumber.
- If you turn the refrigerator on before the water line is connected, turn the ice maker OFF. See “Ice Maker and Storage Bin.”
- All installations must meet local plumbing code requirements.

Water Pressure

A cold water supply with water pressure between 30 and 120 psi (207 and 827 kPa) is required to operate the water dispenser and ice maker. If you have questions about your water pressure, see “Troubleshooting” or call a licensed, qualified plumber.

Reverse Osmosis Water Supply

IMPORTANT: The pressure of the water supply coming out of a reverse osmosis system going to the water inlet valve of the refrigerator needs to be between 30 and 120 psi (207 and 827 kPa).

If a reverse osmosis water filtration system is connected to your cold water supply, the water pressure to the reverse osmosis system needs to be a minimum of 40 psi (276 kPa).

If the water pressure to the reverse osmosis system is less than 40 psi (276 kPa):

- Check to see whether the sediment filter in the reverse osmosis system is blocked. Replace the filter if necessary.
- Allow the storage tank on the reverse osmosis system to refill after heavy usage.

- If your refrigerator has a water filter, it may further reduce the water pressure when used in conjunction with a reverse osmosis system. Remove the water filter. See “Water Filtration System.”

If you have questions about your water pressure, call a licensed, qualified plumber.

Water System Preparation

Please read before using the water system.

IMPORTANT: After connecting the refrigerator to a water source or after replacing the water filter, fill and discard two full containers of ice to prepare the water filter for use before using the ice.

Do not use with water that is microbiologically unsafe or of unknown quality without adequate disinfection before or after the system.

1. To turn on the ice maker, simply lower the wire shutoff arm. See “Ice Maker and Storage Bin” for further instructions on the operation of your ice maker.

NOTE: Allow 24 hours to produce the first batch of ice.

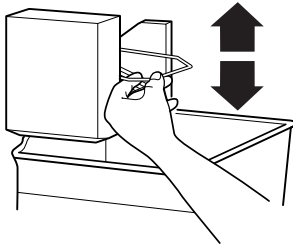

A. On/Off control

NOTE: If your model has a base grille filter system, make sure the base grille filter is installed so that the Eject button is out. See “Water Filtration System.”

Install Air Filter (on some models)

An air filter is 15 times more powerful than baking soda at reducing common food odors inside the refrigerator.

On some models, your refrigerator's accessory packet includes an air filter, which must be installed prior to use.

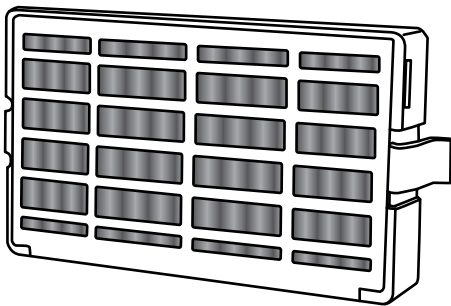

Installing the Air Filter

Install the air filter in the ceiling, along the back wall, of the refrigerator compartment.

1. Remove the air filter from its packaging.
2. Snap the filter into place.

Replacing the Air Filter

The disposable air filter should be replaced every 6 months.

To order a replacement air filter, contact us. See “Accessories” for information on ordering.

1. Remove the used air filter by squeezing in on the side tabs.
2. Install the new air filter by snapping it into place.

Install Produce Preserver (on some models)

The produce preserver absorbs ethylene to slow the ripening process of many produce items. As a result, certain produce items will stay fresh longer.

Ethylene production and sensitivity varies depending on the type of fruit or vegetable. To preserve freshness, it is best to separate produce with sensitivity to ethylene from fruits that produce moderate to high amounts of ethylene.

	Sensitivity to Ethylene	Ethylene Production
Apples	High	Very High
Asparagus	Medium	Very Low
Berries	Low	Low
Broccoli	High	Very Low
Cantaloupe	Medium	High
Carrots	Low	Very Low
Citrus Fruit	Medium	Very Low
Grapes	Low	Very Low
Lettuce	High	Very Low
Pears	High	Very High
Spinach	High	Very Low

Installing the Produce Preserver

CAUTION: IRRITANT

MAY IRRITATE EYES AND SKIN. DANGEROUS FUMES FORM WHEN MIXED WITH OTHER PRODUCTS.

Do not mix with cleaning products containing ammonia, bleach or acids. Do not get in eyes, on skin or clothing. Do not breathe dust. Keep out of reach of children.

FIRST AID TREATMENT: Contains potassium permanganate. If swallowed, call a Poison Control Center or doctor immediately. Do not induce vomiting. If in eyes, rinse with water for 15 minutes. If on skin, rinse with water.

1. Wash the interior of a crisper drawer with a solution of mild dish soap and warm water, and dry thoroughly.
2. Find the package containing the Produce Preserver inside the refrigerator, and install the Produce Preserver into the crisper drawer according to the instructions provided in the package.

Replacing the Produce Preserver

The disposable packets should be replaced every 6 months or when the status indicator changes completely from white to red. To order replacements, contact us. See "Accessories" for information on ordering.

1. Remove the used packets from the produce preserver housing.
2. Remove the used status indicator.
3. Install the replacement packets and status indicator using the instructions included in the package.

REFRIGERATOR USE

⚠ WARNING



Electrical Shock Hazard

Plug into a grounded 3 prong outlet.

Do not remove ground prong.

Do not use an adapter.

Do not use an extension cord.

Failure to follow these instructions can result in death, fire, or electrical shock.

⚠ WARNING



Explosion Hazard

Keep flammable materials and vapors, such as gasoline, away from refrigerator.

Failure to do so can result in death, explosion, or fire.

Power On/Off Switch

If you need to turn the power to your refrigerator On or Off, you must remove the top grille panel to access the power switch. Turn the power to the refrigerator Off when cleaning your refrigerator or changing light bulbs.

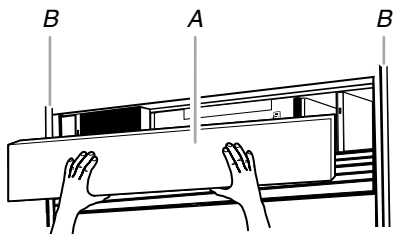

A. Top grille
B. Cabinet sides

Standard Integrated Grille Installation

To remove the top grille panel:

1. Open the door(s).
2. Pull out on the bottom of the panel, and then lift up. Place the panel on a soft surface.

To replace the top grille panel:

1. Hook the panel brackets onto the mounting bolts extending from the top of the refrigerator.
2. Tilt the bottom of the grille panel down slightly to lock into place.

Fully Integrated Grille Installation

To install the grille panel to the refrigerator:

1. Slide the upper and lower slots in each bracket onto the mounting pins extending upward from the top of the refrigerator.
2. Push the grille panel forward to fully engage the spring clips and fasten the grille panel.

To remove the grille panel from the refrigerator:

1. Open the door(s).
2. Place both hands under the grille panel, grasping the bottom edge between your fingers and thumbs.
3. Pull the grille panel straight out until the grille stops. Then, lift up on the grille panel to remove.

Power On or Off Switch

1. Remove the top grille panel.
2. Press power switch to the On or Off position.
3. Replace the top grille panel.

IMPORTANT: Be sure the power switch is set to the On position after cleaning refrigerator or changing light bulbs.

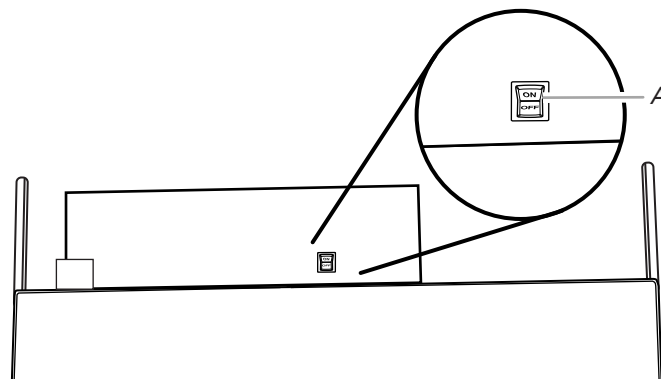

A. Power switch

Using the Controls

IMPORTANT:

- The Fridge control adjusts the temperature in the refrigerator compartment. The Freezer control adjusts the temperature in the freezer compartment.
- Wait 24 hours after you turn on the refrigerator before you put food into it. If you add food before the refrigerator has cooled completely, your food may spoil.

NOTE: Adjusting the temperature controls to a lower (colder) setting will not cool the compartments any faster.

- If the temperature is too warm or too cold in the refrigerator or freezer, first check the air vents to be sure they are not blocked before adjusting the controls.

- The recommended settings should be correct for normal household usage. The controls are set correctly when milk or juice is as cold as you like and when ice cream is firm.
- The actual temperature may differ from the display when a door is open for an extended period of time.

Turning On Cooling and Viewing Set Points

The factory recommended set points are 0°F (-18°C) for the freezer and 37°F (3°C) for the refrigerator

1. Press the FRIDGE or FREEZER touch pad.

NOTE: After the refrigerator is turned on, the Over Temperature audio alarm and indicator light may activate every 1½ hours until the refrigerator and freezer temperatures are below 48°F (9°C) and 15°F (-9°C), respectively, or until the alarm is turned off. To turn off the audio alarm and indicator light, see “Alarm Reset.”

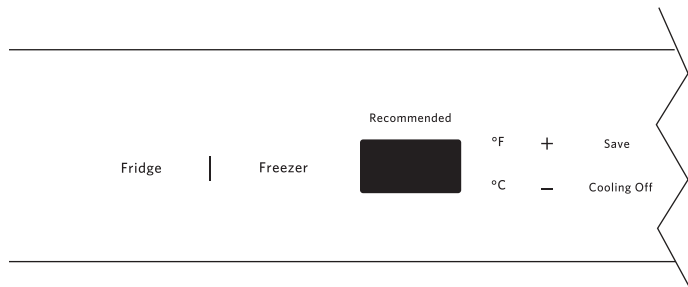

Turning Off Cooling

1. Press the FRIDGE or FREEZER touch pad.
 2. Press and hold the COOLING OFF touch pad for 3 seconds.
- NOTE:** To turn off the power completely, use the power ON/OFF switch located behind the top grille. See “Power On/Off Switch.”

Viewing the Temperature in Degrees Celsius

1. Press °C touch pad. To redisplay degrees Fahrenheit, press °F touch pad.
- NOTE:** If the freezer temperature is below zero, the negative sign next to the freezer display will light up. This is normal.

Adjusting Controls

NOTE: Wait at least 24 hours between adjustments. Recheck the temperatures before other adjustments are made.

To Adjust Set Point Temperatures:

- Press the FRIDGE or FREEZER touch pad, and then press the Plus (+) or Minus (-) touch pad until the desired temperature is reached.
- Press the SAVE touch pad to program the desired temperature.

NOTE: The set point range for the freezer is -5°F to 3°F (-21°C to -16°C). The set point range for the refrigerator is 34°F to 42°F (1°C to 6°C).

CONDITION/REASON:	TEMPERATURE ADJUSTMENT:
REFRIGERATOR too cold Not set correctly for conditions	REFRIGERATOR Control 1° higher
REFRIGERATOR too warm High use or room very warm	REFRIGERATOR Control 1° lower
FREEZER too cold Not set correctly for conditions	FREEZER Control 1° higher
FREEZER too warm/too little ice High use or heavy ice use	FREEZER Control 1° lower

Options

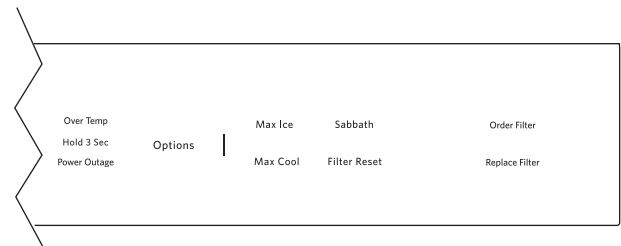

Max Ice

The Max Ice feature speeds up the ice production rate to assist with periods of heavy ice usage.

- Press OPTIONS, and then press MAX ICE to turn on the Max Ice feature. Max Ice will remain activated for 24 hours unless manually turned off.

NOTE: The temperature display for the refrigerator and freezer compartments will remain at the user’s set point, but the actual temperature of the freezer compartment will drop to -5°F (-21°C), while the Max Ice feature is enabled. After 24 hours, the freezer will return to the previous temperature set point.

Max Cool

The Max Cool feature assists with full grocery loads, temporarily warm room temperatures, or during heavy door opening use.

- Press OPTIONS, and then press MAX COOL to turn on the Max Cool feature. Max Cool will remain activated for 24 hours unless manually turned off.

NOTE: The temperature display for the refrigerator compartment will remain at the user’s set point, but the actual temperature of the Fridge compartment will drop to 34°F (1°C), while the Max Cool feature is enabled. After 24 hours, the refrigerator returns to the previous temperature set points.

Sabbath Mode

Sabbath mode is designed for the traveler or for those whose religious observances require turning off the lights and ice maker. By selecting this feature, the temperature set points remain unchanged, the ice maker will be disabled, the interior lights will turn off, and the audio tones are muted. For most efficient refrigerator operation, it is recommended to exit Sabbath mode when it is no longer required.

- Press the SABBATH touch pad to turn on Sabbath mode. This feature will remain on until Sabbath is pressed again.

NOTE: If the Max Cool or Max Ice feature has been selected prior to turning on Sabbath mode, Max Cool and Max Ice will be automatically canceled upon entering Sabbath mode.

Filter Reset

See “Water Filter Indicator” in the “Water Filtration System” section.

Alarm Functions

Alarm Reset

Pressing any Home Screen touch pad (Fridge, Freezer or Options) will turn off the audio alarm and indicator light. The audio alarm will not sound again for the current condition that caused the alarm until a new condition occurs.

An Alarm Reset can be performed by pressing any Home Screen touch pad (Fridge, Freezer or Options), or by turning the power to the refrigerator off and on again. See “Power On/Off Switch.” After performing an Alarm Reset, the indicator light will reactivate if the condition that caused the alarm is still present. See “Door Open,” “Over Temperature” or “Power Outage.”

Door Open

An alarm will sound when a door has been open for longer than 5 minutes. Closing the door or drawer, or pressing any Home Screen touch pad (Fridge, Freezer or Options) will reset the Door Open feature and turn off the audio alarm.

NOTE: If the door(s) or drawer are left open for 10 minutes the interior lights will go out. Closing the open door(s) or drawer will reset the lights.

Over Temperature

IMPORTANT: If the Over Temperature Alarm activates, your food may spoil. See “Power Interruptions.” Minimize door openings until temperatures return to normal.

The Over Temperature feature is designed to let you know when either the refrigerator temperature rises above 48°F (9°C) or the freezer temperature rises above 15°F (-9°C) for longer than 1½ hours. The audio alarm will shut off automatically when the temperature returns to normal, but the indicator light will continue to flash to let you know that an Over Temperature condition occurred until an Over Temperature reset has been performed. Press any Home Screen touch pad (Fridge, Freezer or Options) to turn off the indicator light.

If the over temperature condition is still present when an Over Temperature reset is performed, the indicator light will continue to reactivate every 1½ hours until refrigerator and freezer temperatures are below 48°F (9°C) and 15°F (-9°C), respectively.

Power Outage

When a power outage occurs, a Power Outage indicator light will be displayed. Press any Home Screen touch pad (Fridge, Freezer or Options) to turn off the indicator light. The power outage indicator light will not display when either Cooling Off or Sabbath Mode is active, but will appear after exiting Sabbath mode if a power outage occurred.

Ice Maker and Storage Bin

IMPORTANT: After connecting the refrigerator to a water source or replacing the water filter, fill and discard two full containers of ice to prepare the water filter for use, before using the ice.

Turn the Ice Maker On/Off

1. To turn on the ice maker, simply lower the wire shutoff arm.
NOTE: Your ice maker has an automatic shutoff. As ice is made, the ice cubes will fill the ice storage bin and the ice cubes will raise the wire shutoff arm to the OFF (arm up) position. Do not force the wire shutoff arm up or down.
2. To manually turn off the ice maker, lift the wire shutoff arm to the OFF (arm up) position and listen for the click.

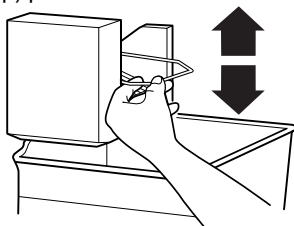

A. On/Off control

Ice Storage Bin Care

NOTE: It is normal for ice to stick together in the ice bin. It is recommended that the ice bin be emptied and cleaned as needed.

To clean the ice storage bin:

1. Slide the ice bin out of the freezer and lift up and out.
2. Empty the ice bin. Use warm water to melt the ice if necessary.
NOTE: Do not use anything sharp to break up the ice in the bin. This can cause damage to the ice bin and the dispenser mechanism.
3. Wash ice bin with warm water and a mild detergent, rinse well and dry thoroughly. Do not use harsh or abrasive cleaners or solvents.

REMEMBER:

- Allow 24 hours to produce the first batch of ice.
 - It may take 3 to 4 days for the ice bin to completely fill, if no ice is used.
 - The quality of your ice will be only as good as the quality of the water supplied to your ice maker.
 - Avoid connecting the ice maker to a softened water supply. Water softener chemicals (such as salt) can damage parts of the ice maker and lead to poor quality ice. If a softened water supply cannot be avoided, make sure the water softener is operating properly and is well maintained.
 - It is normal for the ice cubes to be attached at the corners. They will break apart easily.
 - Do not store anything inside the ice bin.
-

Water Filtration System

Do not use with water that is microbiologically unsafe or of unknown quality without adequate disinfection before or after the system.

Water Filter Indicator (on some models)

The water filter indicator, located on the control panel, will help you know when to change the water filter.

A replacement water filter should be ordered when “Order Filter” is displayed. It is recommended that you replace the filter when “Replace Filter” is displayed or when water flow to your water dispenser and/or ice maker decreases noticeably. See “Changing the Water Filter” later in this section.

After changing the water filter, press and hold FILTER RESET for 3 seconds until the “Order Filter” or “Replace Filter” indicator light disappears.

Changing the Water Filter

The water filter is located in the base grille below the freezer compartment door. It is not necessary to remove the base grille to remove the filter.

1. Remove the filter by pressing the eject button and pulling straight out on the filter cap.

NOTES:

- Avoid twisting the cap when removing the filter because this could cause the cap to come off. If this occurs, replace the cap and pull the filter straight out.
- There will be water in the filter. Some spilling may occur.

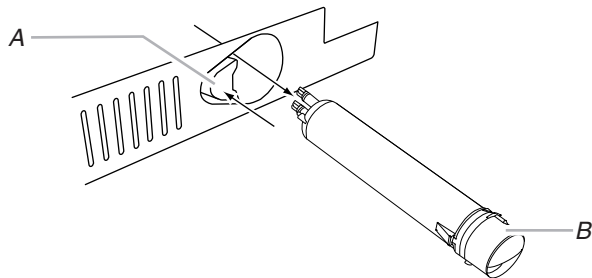

A. Eject button
B. Filter cap

2. Remove the cap by turning it counterclockwise until it stops.
IMPORTANT: Do not discard the cap. It is part of your refrigerator. Keep the cap to use with the replacement filter.
3. Align the ridge on the cap with the arrow on the new filter and turn the cap until it snaps into place.

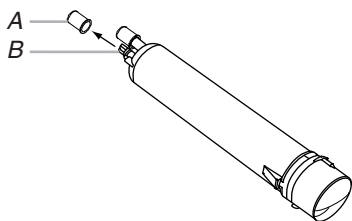

A. Cover
B. O-rings

4. Remove the covers from the O-rings. Be sure the O-rings are still in place after the covers are removed.
5. Place the cap (removed in Step 2) on the new filter. Align the ridge on the cap with the arrow on the filter. Turn the cap clockwise until it snaps into place.

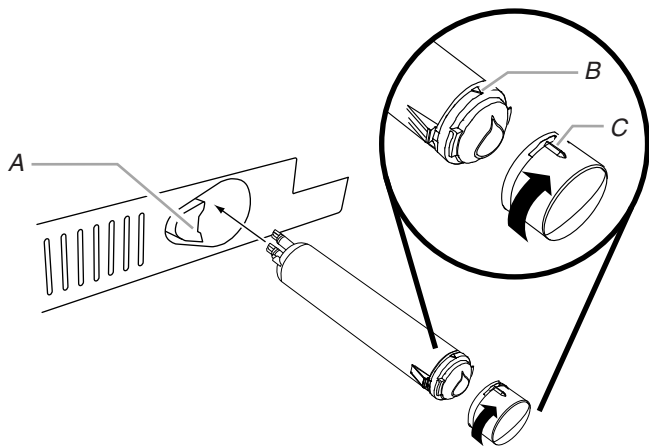

A. Eject button
B. Arrow on filter
C. Ridge on cap

6. Push the new filter into the opening in the base grille. As the filter is inserted, the eject button will depress. The eject button will pop back out when the filter is fully engaged.
7. Pull gently on the cap to check that the filter is securely in place.
8. Flush the water system. Depending on your model, see "Water and Ice Dispensers" or "Ice Maker and Storage Bin."

Using the Ice Maker Without a Water Filter

You can operate the ice maker without a water filter. Your ice will not be filtered.

1. Remove the filter by pressing the eject button and pulling on the cap. See "Changing the Water Filter" earlier in this section.
2. Remove the cap by turning it counterclockwise until it stops.
IMPORTANT: Do not discard the cap. It is part of your refrigerator.
3. With the cap in a horizontal position, insert the cap into the base grille until it stops.

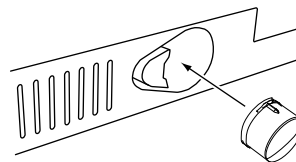

4. Turn the cap counterclockwise until the cap slips into the attachment slot. Then, turn the cap clockwise until it is in a horizontal position.

NOTE: The cap will not be even with the base grille.

REFRIGERATOR FEATURES

Refrigerator Shelves

Important information to know about glass shelves and covers:

Do not clean glass shelves or covers with warm water when they are cold. Shelves and covers may break if exposed to sudden temperature changes or impact, such as bumping. Tempered glass is designed to shatter into many small, pebble-size pieces. This is normal. Glass shelves and covers are heavy. Use both hands when removing them to avoid dropping.

The shelves in your refrigerator are adjustable to meet your individual storage needs.

Storing similar food items together in your refrigerator and adjusting the shelves to fit different heights of items will make finding the exact item you want easier. It will also reduce the amount of time the refrigerator door is open, and save energy.

Shelves and Shelf Frames

To remove and replace the shelf/frame:

1. Remove the shelf by tilting it up at the front and lifting it out of the shelf supports. Pull shelf straight out.
2. Reposition the shelf supports in the desired location. Check that they are level and firmly inserted in the support rails.

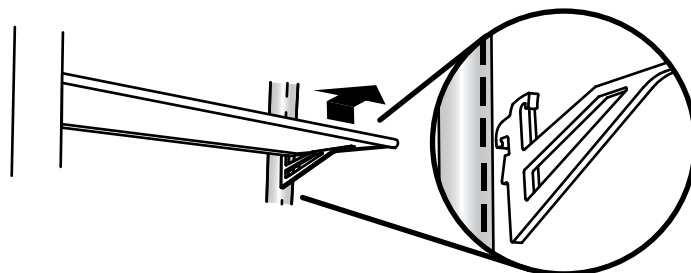

3. Place the back of the shelf in the shelf supports.
4. Lower the front of the shelf and make sure that it is in position.

Meat Storage Guide

Store most meat in original wrapping as long as it is airtight and moisture-proof. Rewrap if necessary. See the following chart for storage times. When storing meat longer than the times given, freeze the meat.

Fresh fish or shellfish use same day as purchased
Chicken, ground beef, variety meat (liver, etc.)..... 1-2 days
Cold cuts, steaks/roasts 3-5 days
Cured meats 7-10 days
Leftovers - Cover leftovers with plastic wrap, aluminum foil, or plastic containers with tight lids.

Deli/Crisper Drawers

To remove and replace the deli/cripper drawers:

1. Slide the deli/cripper drawer straight out to the stop. Lift the front of the drawer with one hand while supporting the bottom with the other hand. Slide the drawer out the rest of the way.
 2. To replace the deli/cripper drawer, pull out the drawer slides until they are fully extended and set the drawer on the slides. Push the drawer in toward the back until it is in closed position.
 3. Reopen the deli/cripper drawer to make sure it has been replaced properly.
-

Wine Rack

To remove and replace the wine rack:

1. Remove the rack by pulling it straight out from the shelf.
2. Replace the rack by sliding it in between the shelf and the wall of the refrigerator.

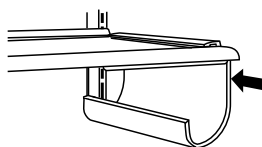

FREEZER FEATURES

Freezer Drawer and Pull-out Ice Bin

The freezer drawer can be used to store smaller items. The freezer drawer is not removable.

To remove and replace the ice bin:

1. Slide the ice bin out of the freezer and lift up and out.

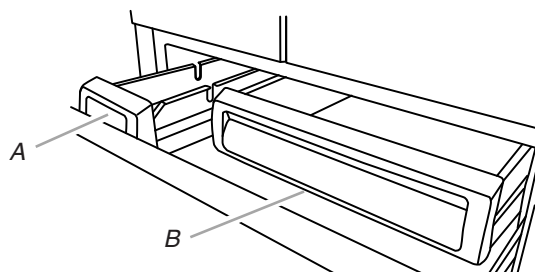

A. Ice bin
B. Freezer drawer

2. To replace the ice bin, pull out the drawer slides until they are fully extended and set ice bin on the slides. Push the ice bin in toward the back until it is in closed position.
 3. Reopen the ice bin to make sure it has been replaced properly.
-

Frozen Food Storage Guide

Storage times will vary according to the quality and type of food, the type of packaging or wrap used (should be airtight and moisture-proof), and the storage temperature. Ice crystals inside a sealed package are normal. This simply means that moisture in the food and air inside the package have condensed, creating ice crystals.

Put no more unfrozen food into the freezer than will freeze within 24 hours (no more than 2 to 3 lbs of food per cubic foot [907-1,350 g per 28 L] of freezer space). Leave enough space in the freezer for air to circulate around packages. Be sure to leave enough room for the door to close tightly.

For more information on preparing food for freezing, check a freezer guide or reliable cookbook.

DOOR FEATURES

Utility Compartment (on some models)

The utility compartment can be placed in any position on the refrigerator door.

To remove and replace the utility bin:

1. Remove utility compartment by grasping both ends and lifting compartment up and out.
2. Replace the bin by sliding it in above the desired support and pushing it down until it stops.

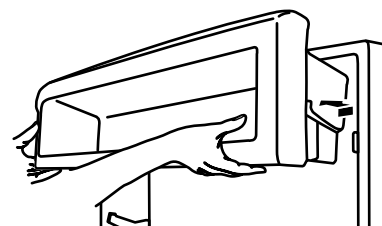

Door Bins

Large door bins hold gallon containers and the smaller door bins hold 2-liter bottles. The door bins are adjustable and removable for easy cleaning and adjusting.

Gallon Door Bin

To install the gallon door bin:

NOTE: The gallon door bin can only be placed on the lower door support.

1. Position gallon door bin above lowest door adjustment slot.
 2. Push down to secure bin.
 3. Adjust other bins, as necessary, to allow for milk or beverage container height.
-

Door Bins

To remove and replace the door bins:

1. Remove the bin by lifting it up and pulling it out.

2. Replace the bin by sliding it in above the desired support and pushing it down until it stops.

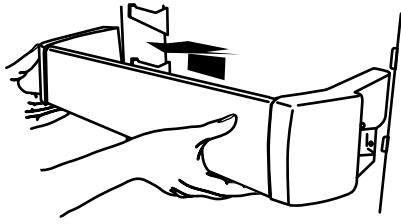

REFRIGERATOR CARE

Cleaning

⚠ WARNING



Explosion Hazard

Use nonflammable cleaner.

Failure to do so can result in death, explosion, or fire.

Both the refrigerator and freezer sections defrost automatically. However, clean both sections about once a month to avoid buildup of odors. Wipe up spills immediately.

To Clean Your Refrigerator:

1. Remove the top grille. See "Power On/Off Switch."
2. Press the power switch to OFF.
3. Remove all removable parts from inside, such as shelves, crispers, etc.

4. Hand wash, rinse, and dry removable parts and interior surfaces thoroughly. Use a clean sponge or soft cloth and a mild detergent in warm water.
 - Do not use abrasive or harsh cleaners such as window sprays, scouring cleansers, flammable fluids, cleaning waxes, concentrated detergents, bleaches or cleansers containing petroleum products on plastic parts, interior and door liners or gaskets. Do not use paper towels, scouring pads, or other harsh cleaning tools. These can scratch or damage materials.
 - To help remove odors, you can wash interior walls with a mixture of warm water and baking soda (2 tbs to 1 qt [26 g to 0.95 L] of water).
5. Clean the exterior surfaces.

Stainless steel panels: Wash stainless steel with a clean sponge or soft cloth and a mild detergent in warm water.

 - To keep your stainless steel refrigerator looking like new and to remove minor scuffs or marks, it is suggested that you use the manufacturer's approved Stainless Steel Cleaner and Polish.

IMPORTANT: This cleaner is for Stainless Steel parts only!

Do not allow the Stainless Steel Cleaner and Polish to come into contact with any plastic parts such as the trim pieces, dispenser covers or door gaskets. If unintentional contact does occur, clean plastic part with a sponge and mild detergent in warm water. Dry thoroughly with a soft cloth. To order the cleaner, see "Accessories."
6. Press the power switch to ON.
7. Replace the top grille. See "Power On/Off Switch."

Lights

The lights in both the refrigerator and freezer compartments are LEDs which do not need to be replaced. If the lights do not illuminate when the door or drawer is opened, call for assistance or service. In the U.S.A., call **1-800-422-1230**. In Canada call **1-800-807-6777**.

Power Interruptions

If the power will be out for 24 hours or less, keep the door or doors closed (depending on your model) to help food stay cold and frozen.

If the power will be out for more than 24 hours, do one of the following:

- Remove all frozen food and store it in a frozen food locker.
- Place 2 lbs (907 g) of dry ice in the freezer for every cubic foot (28 L) of freezer space. This will keep the food frozen for 2 to 4 days.
- If neither a food locker nor dry ice is available, consume or can perishable food at once.

REMEMBER: A full freezer stays cold longer than a partially filled one. A freezer full of meat stays cold longer than a freezer full of baked goods. If you see that food contains ice crystals, it may be refrozen, although the quality and flavor may be affected. If the condition of the food is poor, dispose of it.

Vacation Care

Your refrigerator is equipped with the Sabbath Mode feature, which is designed for the traveler or for those whose religious observances require turning off the lights and ice maker. By selecting this feature, the temperature set points remain unchanged, the ice maker will be disabled and the interior lights will turn off. For most efficient refrigerator operation, it is recommended to exit Sabbath mode when it is no longer required.

If You Choose to Leave the Refrigerator On While You're Away:

1. Use up any perishables and freeze other items.
2. Press the SABBATH touch pad.
3. If your refrigerator has an automatic ice maker, shut off the water supply to the ice maker.
4. Empty the ice bin.
5. When you return from vacation, press the SABBATH touch pad to return to normal operation.

If You Choose to Turn the Refrigerator Off Before You Leave:

1. Remove all food from the refrigerator.
2. If your refrigerator has an automatic ice maker:
 - Turn off the water supply to the ice maker at least one day ahead of time.
 - When the last load of ice drops, slide the ice maker control to the OFF (down) position.
3. Under the Fridge or Freezer menu, press and hold COOLING OFF for 3 seconds to turn off cooling.
NOTE: To turn off the power completely, use the power ON/OFF switch located behind the top grille. See "Power On/Off Switch."
4. Clean refrigerator, wipe it, and dry well.
5. Tape rubber or wood blocks to the tops of all doors to prop them open far enough for air to get in. This stops odor and mold from building up.

TROUBLESHOOTING

Try the solutions suggested here first in order to avoid the cost of an unnecessary service call.

Refrigerator Operation

The refrigerator will not operate

⚠ WARNING



Electrical Shock Hazard

- Plug into a grounded 3 prong outlet.
- Do not remove ground prong.
- Do not use an adapter.
- Do not use an extension cord.
- Failure to follow these instructions can result in death, fire, or electrical shock.

- **Power cord unplugged?** Plug into a grounded 3 prong outlet.
- **Is outlet working?** Plug in a lamp to see if the outlet is working.
- **Household fuse blown or circuit breaker tripped?** Replace the fuse or reset the circuit breaker. If the problem continues, call an electrician.
- **Are controls on?** Make sure the refrigerator controls are on. See "Using the Controls."
- **Is refrigerator defrosting?** Your refrigerator will regularly run an automatic defrost cycle. Recheck in 30 minutes to see if it is operating.

- **New installation?** Allow 24 hours following installation for the refrigerator to cool completely.

NOTE: Adjusting the temperature controls to the coldest setting will not cool either compartment more quickly.

The motor seems to run too much

Your new refrigerator may run longer than your old one due to its high-efficiency compressor and fans. The unit may run even longer if the room is warm, a large food load is added, doors are opened often, or if the doors have been left open.

The refrigerator is noisy

Refrigerator noise has been reduced over the years. Due to this reduction, you may hear intermittent noises from your new refrigerator that you did not notice from your old model. Below are listed some normal sounds with an explanation.

- **Buzzing** - heard when the water valve opens to fill the ice maker
- **Pulsating** - fans/compressor adjusting to optimize performance
- **Rattling** - flow of refrigerant, water line, or from items placed on top of the refrigerator
- **Sizzling/Gurgling** - water dripping on the heater during defrost cycle
- **Popping** - contraction/expansion of inside walls, especially during initial cool-down
- **Water running** - may be heard when ice melts during the defrost cycle and runs into the drain pan
- **Creaking/Cracking** - occurs as ice is being ejected from the ice maker mold

There is no audible door open alarm

Has the door been open less than 5 minutes? The door open alarm will only flash when the door has been open for 5 minutes. The audible alarm will sound the first time the door is left open for more than 5 minutes. Subsequent door open alarms will only flash. You must reset the audible alarm each time. See “Using the Control(s).”

The doors will not close completely

- **Door blocked open?** Move food packages away from door.
- **Bin or shelf in the way?** Push bin or shelf back in the correct position.

The doors are difficult to open

WARNING



Explosion Hazard

Use nonflammable cleaner.

Failure to do so can result in death, explosion, or fire.

- **Are the gaskets dirty or sticky?** Clean gaskets with mild soap and warm water.

The lights do not work

- **Is the refrigerator in Sabbath mode?** See “Using the Controls.”
- **Has the door been open more than 10 minutes?** See “Using the Controls.”

Temperature and Moisture

Temperature is too warm

- **New installation?** Allow 24 hours following installation for the refrigerator to cool completely.
- **Door(s) opened often or left open?** Allows warm air to enter refrigerator. Minimize door openings and keep doors fully closed.
- **Large load of food added?** Allow several hours for refrigerator to return to normal temperature.
- **Controls set correctly for the surrounding conditions?** Adjust the controls to a colder setting. Check temperature in 24 hours. See “Using the Controls.”
- **Refrigerator not cooling?** For models with digital controls, turn the refrigerator OFF and then ON to reset. If this does not correct the problem, call for service.
- **Air vents blocked?** Remove any item from in front of the air vents.

There is interior moisture buildup

NOTE: Some moisture buildup is normal.

- **Humid room?** Contributes to moisture buildup.

- **Door(s) opened often or left open?** Allows humid air to enter refrigerator. Minimize door openings and keep doors fully closed.

Ice and Water

The ice maker is not producing ice or not enough ice

- **Refrigerator connected to a water supply and the supply shutoff valve turned on?** Connect refrigerator to water supply and turn water shutoff valve fully open.
- **Kink in the water source line?** A kink in the line can reduce water flow. Straighten the water source line.
- **Ice maker turned on?** Make sure wire shutoff arm or switch (depending on model) is in the ON position.
- **New installation?** Wait 24 hours after ice maker installation for ice production to begin. Wait 72 hours for full ice production.
- **Large amount of ice recently removed?** Allow 24 hours for ice maker to produce more ice.
- **Ice cube jammed in the ice maker ejector arm?** Remove ice from the ejector arm with a plastic utensil.
- **Reverse osmosis water filtration system connected to your cold water supply?** This can decrease water pressure. See “Water Supply Requirements” in either the Installation Instruction booklet or the Use & Care Guide.

The ice cubes are hollow or small

NOTE: This is an indication of low water pressure.

- **Water shutoff valve not fully open?** Turn the water shutoff valve fully open.
- **Kink in the water source line?** A kink in the line can reduce water flow. Straighten the water source line.
- **Reverse osmosis water filtration system connected to your cold water supply?** This can decrease water pressure. See “Water Supply Requirements.”
- **Questions remain regarding water pressure?** Call a licensed, qualified plumber.

Ice is sticking together in the ice storage bin

- It is normal for frost to be on top of the ice storage bin due to normal opening and closing of the freezer.
- It is normal for ice to stick together when it is not dispensed or used frequently. It is recommended that the ice storage bin be emptied and cleaned as needed. See “Ice Maker and Storage Bin.”

Off-taste, odor or gray color in the ice

- **New plumbing connections?** New plumbing connections can cause discolored or off-flavored ice.
- **Ice stored too long?** Discard ice. Wash ice bin. Allow 24 hours for ice maker to make new ice.
- **Odor transfer from food?** Use airtight, moisture-proof packaging to store food.
- **Are there minerals (such as sulfur) in the water?** A water filter may need to be installed to remove the minerals.
- **Is there a water filter installed on the refrigerator?** Gray or dark discoloration in ice indicates that the water filtration system needs additional flushing.

ASSISTANCE OR SERVICE

If You Need Service

Please refer to the warranty page in this manual.

If You Need Replacement Parts

If you need to order replacement parts, we recommend that you use only factory specified parts. Factory specified parts will fit right and work right because they are made with the same precision used to build every new Jenn-Air® appliance.

To locate factory specified parts in your area, call us or your nearest designated service center.

In the U.S.A.

Call the Jenn-Air Customer eXperience Center toll free **1-800-JENNAIR (1-800-536-6247)**, or visit our website at **www.jennair.com**.

Our consultants provide assistance with:

- Features and specifications on our full line of appliances.
- Referrals to local Jenn-Air brand dealers.
- Installation information.
- Use and maintenance procedures.
- Accessory and repair parts sales.
- Specialized customer assistance (Spanish speaking, hearing impaired, limited vision, etc.).

For Further Assistance

If you need further assistance, you can write to Jenn-Air with any questions or concerns at:

Jenn-Air Brand Home Appliances
Customer eXperience Center
553 Benson Road
Benton Harbor, MI 49022-2692

Please include a daytime phone number in your correspondence.

In Canada

Call the Jenn-Air Canada LP Customer eXperience Centre toll free **1-800-JENNAIR (1-800-536-6247)**, or visit our website at **www.jennair.ca**.

Our consultants provide assistance with:

- Scheduling of service. Jenn-Air® appliances designated service technicians are trained to fulfill the product warranty and provide after-warranty service, anywhere in Canada.
- Features and specifications on our full line of appliances.
- Referrals to local Jenn-Air brand dealers.
- Use and maintenance procedures.
- Accessory and repair parts sales.

For Further Assistance

If you need further assistance, you can write to Jenn-Air Canada with any questions or concerns at:

Jenn-Air Brand Home Appliances
Customer eXperience Centre
200 – 6750 Century Ave.
Mississauga, Ontario L5N 0B7

Please include a daytime phone number in your correspondence.

ACCESSORIES

To order accessories, call **1-800-442-9991** and ask for the appropriate part number listed below or contact your authorized Jenn-Air® brand dealer. In Canada, call **1-800-807-6777**.

affresh® Stainless Steel Cleaner:

In U.S.A., order Part #W10355016

In Canada, order Part #W10355016B

affresh® Stainless Steel Wipes:

In U.S.A., order Part #W10355049

In Canada, order Part #W10355049B

affresh® Kitchen & Appliance Cleaner:

In U.S.A., order Part #W10355010

In Canada, order Part #W10355010B

Replacement Water Filter:

In U.S.A., order Part #4396841 (T2RFWG2)

In Canada, Order Part #4396841B (T2RFWG2)

Air Filter:

Order Part #W10311524

Produce Preserver Keep Fresh Packet Refill:

Order Part #P1KC6R1

WATER FILTER CERTIFICATIONS

State of California
Department of Health Services
Water Treatment Device
Certificate Number

05 - 1703

Date Issued: April 6, 2005
Date Revised: September 7, 2005

State of California
Department of Health Services
Water Treatment Device
Certificate Number

05 - 1702

Date Issued: April 6, 2005
Date Revised: September 7, 2005

<u>Trademark/Model Designation</u>	<u>Replacement Elements</u>
Whirlpool Deluxe T2WG2	T2RFGW2
Whirlpool Deluxe T2WG2L	T2RFGW2
KitchenAid Deluxe T2WG2	T2RFGW2
KitchenAid Deluxe T2WG2L	T2RFGW2

Manufacturer: Whirlpool Corporation

The water treatment device(s) listed on this certificate have met the testing requirements pursuant to Section 116830 of the Health and Safety Code for the following health related contaminants:

<u>Microbiological Contaminants and Turbidity</u>	<u>Inorganic/Radiological Contaminants</u>
None	Lead Mercury

Organic Contaminants

- Benzene
- Carbofuran
- o-Dichlorobenzene
- Toxaphene

Rated Service Capacity: 200 gals **Rated Service Flow:** 0.85 gpm

Conditions of Certification:
Do not use with water that is microbiologically unsafe or of unknown quality, without adequate disinfection before or after the system.

<u>Trademark/Model Designation</u>	<u>Replacement Elements</u>
Whirlpool Deluxe T1WG2	T2RFGW2
Whirlpool Deluxe T1WG2L	T2RFGW2
KitchenAid Deluxe T1WG2	T2RFGW2
KitchenAid Deluxe T1WG2L	T2RFGW2

Manufacturer: Whirlpool Corporation

The water treatment device(s) listed on this certificate have met the testing requirements pursuant to Section 116830 of the Health and Safety Code for the following health related contaminants:

<u>Microbiological Contaminants and Turbidity</u>	<u>Inorganic/Radiological Contaminants</u>
None	Lead Mercury

Organic Contaminants

- Benzene
- Carbofuran
- o-Dichlorobenzene
- Toxaphene

Rated Service Capacity: 200 gals **Rated Service Flow:** 0.5 gpm

Conditions of Certification:
Do not use with water that is microbiologically unsafe or of unknown quality, without adequate disinfection before or after the system.

PERFORMANCE DATA SHEETS

Base Grille Water Filtration System Model T2WG2L/T2RFGW2 Capacity 200 Gallons (757 Liters) Model T2WG2/T2RFGW2 Capacity 200 Gallons (757 Liters)



System tested and certified by NSF International against NSF/ANSI Standard 42 for the reduction of Chlorine Taste and Odor, Particulate Class II*; and against NSF/ANSI Standard 53 for the reduction of Mercury, Benzene, Toxaphene, O-dichlorobenzene, and Carbofuran.

This system has been tested according to NSF/ANSI Standards 42 and 53 for the reduction of the substances listed below. The concentration of the indicated substances in water entering the system was reduced to a concentration less than or equal to the permissible limit for water leaving the system, as specified in NSF/ANSI Standards 42 and 53.

Substance Reduction	NSF Reduction Requirements	Average Influent	Influent Challenge Concentration	Maximum Effluent	Average Effluent	Minimum % Reduction	Average % Reduction
Chlorine Taste/Odor	50% reduction	2.0182 mg/L	2.0 mg/L ± 10%	0.06 mg/L	0.0536 mg/L	97.03	97.34
Particulate Class II*	85% reduction	1333333 #/mL	At least 10,000 particles/mL	6600 #/mL**	2325 #/mL	99.51	99.83
Contaminant Reduction	NSF Reduction Requirements	Average Influent	Influent Challenge Concentration	Maximum Effluent	Average Effluent	Minimum % Reduction	Average % Reduction
Lead: @ pH 6.5***	0.010 mg/L	0.1533 mg/L	0.15 mg/L ± 10%	0.0005 mg/L	0.0005 mg/L	99.67	99.67
Lead: @ pH 8.5***	0.010 mg/L	0.1400 mg/L	0.15 mg/L ± 10%	0.0007 mg/L	0.0006 mg/L	99.50	99.57
Mercury: @ pH 6.5	0.002 mg/L	0.0058 mg/L	0.006 mg/L ± 10%	0.0002 mg/L	0.0002 mg/L	96.54	96.54
Mercury: @ pH 8.5	0.002 mg/L	0.0059 mg/L	0.006 mg/L ± 10%	0.0005 mg/L	0.0003 mg/L	91.57	94.92
Benzene	0.005 mg/L	0.0154 mg/L	0.015 mg/L ± 10%	0.0012 mg/L	0.0006 mg/L	92.22	96.34
O-Dichlorobenzene	0.6 mg/L	1.7571 mg/L	1.8 mg/L ± 10%	0.0250 mg/L	0.0066 mg/L	98.58	99.63
Toxaphene	0.003 mg/L	0.015 mg/L	0.015 mg/L ± 10%	0.001 mg/L	0.001 mg/L	93.33	93.33
Carbofuran	0.04 mg/L	0.0819 mg/L	0.08 mg/L ± 10%	0.0400 mg/L	0.0213 mg/L	51.13	74.00

Test Parameters: pH = 7.5 ± 0.5 unless otherwise noted. Flow = 0.85 gpm (3.2 Lpm). Pressure = 60 psig (413.7 kPa). Temp. = 68°F to 71.6°F (20°C to 22°C). Rated service capacity = 200 gallons (757 liters).

- It is essential that operational, maintenance, and filter replacement requirements be carried out for the product to perform as advertised.
- Use replacement filter T2RFGW2, part #4396841.
 - Model T2WG2L: Style 1** – When the filter indicator reads 10%, order a new filter. When the indicator reads 0%, it is recommended that you replace the filter.
 - Style 2** – When the filter indicator changes from green to yellow, order a new filter. When the indicator changes from yellow to red, it is recommended that you replace the filter.
 - Style 3** – When the water filter status display changes from “GOOD” to “ORDER,” order a new filter. When the filter indicator reads “REPLACE,” it is recommended that you replace the filter.
 - Style 4** – Press FILTER to check the status of your water filter. If the filter indicator light is yellow, order a new filter. If the filter indicator light is red, it is recommended that you replace the filter.
- Model T2WG2:** Change the water filter cartridge every 6 months. If the water flow to the water dispenser or ice maker decreases noticeably before 6 months have passed, replace the water filter cartridge more often.
- These contaminants are not necessarily in your water supply. While testing was performed under standard laboratory conditions, actual performance may vary.
- The product is for cold water use only.
- Do not use with water that is microbiologically unsafe or of unknown quality without adequate disinfection before or after the system.
- Refer to the “Warranty” section for the Manufacturer’s name, address and telephone number.
- Refer to the “Warranty” section for the Manufacturer’s limited warranty.

Application Guidelines/Water Supply Parameters

Water Supply	City or Well
Water Pressure	30 - 120 psi (207 - 827 kPa)
Water Temperature	33° - 100°F (0.6° - 37.8°C)
Service Flow Rate	0.85 gpm (3.2 Lpm) @ 60 psi

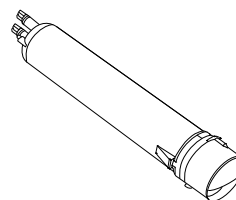

*Class II particle size: 1 um to <5 um

**Test requirement is at least 100,000 particles/mL of AC Fine Test Dust.

***Compliant for Lead reduction requirements under NSF/ANSI Standard 53 as tested by Pace Analytical Services, Inc.

® NSF is a registered trademark of NSF International.

Base Grille Water Filtration System

Model T1WG2L/T2RFGW2 Capacity 200 Gallons (757 Liters)

Model T1WG2/T2RFGW2 Capacity 200 Gallons (757 Liters)



System tested and certified by NSF International against NSF/ANSI Standard 42 for the reduction of Chlorine Taste and Odor, Particulate Class II*; and against NSF/ANSI Standard 53 for the reduction of Mercury, Benzene, Toxaphene, O-dichlorobenzene, and Carbofuran.

This system has been tested according to NSF/ANSI Standards 42 and 53 for the reduction of the substances listed below. The concentration of the indicated substances in water entering the system was reduced to a concentration less than or equal to the permissible limit for water leaving the system, as specified in NSF/ANSI Standards 42 and 53.

Substance Reduction	NSF Reduction Requirements	Average Influent	Influent Challenge Concentration	Maximum Effluent	Average Effluent	Minimum % Reduction	Average % Reduction
Chlorine Taste/Odor	50% reduction	2.0182 mg/L	2.0 mg/L ± 10%	0.06 mg/L	0.0536 mg/L	97.03	97.34
Particulate Class II*	85% reduction	1333333 #/mL	At least 10,000 particles/mL	6600 #/mL**	2325 #/mL	99.51	99.83
Contaminant Reduction	NSF Reduction Requirements	Average Influent	Influent Challenge Concentration	Maximum Effluent	Average Effluent	Minimum % Reduction	Average % Reduction
Lead: @ pH 6.5***	0.010 mg/L	0.1533 mg/L	0.15 mg/L ± 10%	0.0005 mg/L	0.0005 mg/L	99.67	99.67
Lead: @ pH 8.5***	0.010 mg/L	0.1400 mg/L	0.15 mg/L ± 10%	0.0007 mg/L	0.0006 mg/L	99.50	99.57
Mercury: @ pH 6.5	0.002 mg/L	0.0058 mg/L	0.006 mg/L ± 10%	0.0002 mg/L	0.0002 mg/L	96.54	96.54
Mercury: @ pH 8.5	0.002 mg/L	0.0059 mg/L	0.006 mg/L ± 10%	0.0005 mg/L	0.0003 mg/L	91.57	94.92
Benzene	0.005 mg/L	0.0154 mg/L	0.015 mg/L ± 10%	0.0012 mg/L	0.0006 mg/L	92.22	96.34
O-Dichlorobenzene	0.6 mg/L	1.7571 mg/L	1.8 mg/L ± 10%	0.0250 mg/L	0.0066 mg/L	98.58	99.63
Toxaphene	0.003 mg/L	0.015 mg/L	0.015 mg/L ± 10%	0.001 mg/L	0.001 mg/L	93.33	93.33
Carbofuran	0.04 mg/L	0.0819 mg/L	0.08 mg/L ± 10%	0.0400 mg/L	0.0213 mg/L	51.13	74.00

Test Parameters: pH = 7.5 ± 0.5 unless otherwise noted. Flow = 0.5 gpm (1.9 Lpm). Pressure = 60 psig (413.7 kPa). Temp. = 68°F to 71.6°F (20°C to 22°C). Rated service capacity = 200 gallons (757 liters).

- It is essential that operational, maintenance, and filter replacement requirements be carried out for the product to perform as advertised.
- Use replacement filter T2RFGW2, part #4396841.
 - Model T1WG2L: Style 1** – When the filter indicator reads 10%, order a new filter. When the indicator reads 0%, it is recommended that you replace the filter.
 - Style 2** – When the filter indicator changes from green to yellow, order a new filter. When the indicator changes from yellow to red, it is recommended that you replace the filter.
 - Style 3** – When the water filter status display changes from “GOOD” to “ORDER,” order a new filter. When the filter indicator reads “REPLACE,” it is recommended that you replace the filter.
 - Style 4** – Press FILTER to check the status of your water filter. If the filter indicator light is yellow, order a new filter. If the filter indicator light is red, it is recommended that you replace the filter.
- **Model T1WG2:** Change the water filter cartridge every 6 months. If the water flow to the water dispenser or ice maker decreases noticeably before 6 months have passed, replace the water filter cartridge more often.
- These contaminants are not necessarily in your water supply. While testing was performed under standard laboratory conditions, actual performance may vary.
- The product is for cold water use only.
- Do not use with water that is microbiologically unsafe or of unknown quality without adequate disinfection before or after the system.
- Refer to the “Warranty” section for the Manufacturer’s name, address and telephone number.
- Refer to the “Warranty” section for the Manufacturer’s limited warranty.

Application Guidelines/Water Supply Parameters

Water Supply	City or Well
Water Pressure	30 - 120 psi (207 - 827 kPa)
Water Temperature	33° - 100°F (0.6° - 37.8°C)
Service Flow Rate	0.5 gpm (1.9 Lpm) @ 60 psi

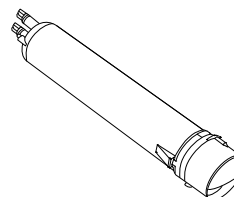

*Class II particle size: 1 um to <5 um

**Test requirement is at least 100,000 particles/mL of AC Fine Test Dust.

***Compliant for Lead reduction requirements under NSF/ANSI Standard 53 as tested by Pace Analytical Services, Inc.

JENN-AIR® REFRIGERATION LIMITED WARRANTY

ATTACH YOUR RECEIPT HERE. PROOF OF PURCHASE IS REQUIRED TO OBTAIN WARRANTY SERVICE.

Please have the following information available when you call the Customer eXperience Center:

- Name, address and telephone number
- Model number and serial number
- A clear, detailed description of the problem
- Proof of purchase including dealer or retailer name and address

IF YOU NEED SERVICE:

1. Before contacting us to arrange service, please determine whether your product requires repair. Some questions can be addressed without service. Please take a few minutes to review the Troubleshooting or Problem Solver section of the Use and Care Guide, scan the QR code on the right to access additional resources, or visit <https://jennair.custhelp.com>.
2. All warranty service is provided exclusively by our authorized Jenn-Air Service Providers. In the U.S. and Canada, direct all requests for warranty service to:

Jenn-Air Customer eXperience Center
1-800-JENNAIR (1-800-536-6247)



<https://jennair.custhelp.com>

If outside the 50 United States or Canada, contact your authorized Jenn-Air dealer to determine whether another warranty applies.

TWELVE YEAR LIMITED WARRANTY

WHAT IS COVERED

TWO YEAR LIMITED WARRANTY

For two years from the date of purchase, when this major appliance is installed, operated and maintained according to instructions attached to or furnished with the product, Jenn-Air brand of Whirlpool Corporation or Whirlpool Canada LP (hereafter "Jenn-Air") will pay for Factory Specified Replacement Parts and repair labor to correct defects in materials or workmanship that existed when this major appliance was purchased, or at its sole discretion replace the product. In the event of product replacement, your appliance will be warranted for the remaining term of the original unit's warranty period.

THIRD THROUGH SIXTH YEAR LIMITED WARRANTY (SEALED REFRIGERATION SYSTEM ONLY)

In the third through sixth year from the date of purchase, when this major appliance is installed, operated and maintained according to instructions attached to or furnished with the product, Jenn-Air brand will pay for factory specified replacement parts and repair labor for the following components to correct non-cosmetic defects in materials or workmanship in the sealed refrigeration system (includes compressor, evaporator, condenser, dryer and connecting tubing) that existed when this major appliance was purchased.

SEVENTH THROUGH TWELFTH YEAR LIMITED WARRANTY (SEALED REFRIGERATION SYSTEM ONLY - LABOR NOT INCLUDED)

In the seventh through twelfth year from the date of purchase, when this major appliance is installed, operated and maintained according to instructions attached to or furnished with the product, Jenn-Air brand will pay for factory specified replacement parts for the following components to correct defects in materials or workmanship in the sealed refrigeration system (includes compressor, evaporator, condenser, dryer and connecting tubing) that existed when this major appliance was purchased.

YOUR SOLE AND EXCLUSIVE REMEDY UNDER THIS LIMITED WARRANTY SHALL BE PRODUCT REPAIR AS PROVIDED HEREIN. Service must be provided by a Jenn-Air designated service company. This limited warranty is valid only in the United States or Canada and applies only when the major appliance is used in the country in which it was purchased. This limited warranty is effective from the date of original consumer purchase. Proof of original purchase date is required to obtain service under this limited warranty.

WHAT IS NOT COVERED

1. Commercial, non-residential or multiple-family use, or use inconsistent with published user, operator or installation instructions.
2. In-home Instruction on how to use your product
3. Service to correct improper product maintenance or installation, installation not in accordance with electrical or plumbing codes or correction of household electrical or plumbing (i.e. house wiring, fuses or water inlet hoses).
4. Consumable parts (i.e. light bulbs, batteries, air or water filters, preservation solutions, etc.).
5. Damage from accident, misuse, abuse, fire, floods, acts of God or use with products not approved by Jenn-Air.
6. Repairs to parts or systems to correct product damage or defects caused by unauthorized service, alteration or modification of the appliance.
7. Cosmetic damage including scratches, dents, chips, and other damage to appliance finishes unless such damage results from defects in materials and workmanship and is reported to Jenn-Air within 30 days.
8. Discoloration, rust or oxidation of surfaces resulting from caustic or corrosive environments including but not limited to high salt concentrations, high moisture or humidity or exposure to chemicals.
9. Food or medicine loss due to product failure.
10. Pick-up or delivery. This product is intended for in-home repair.
11. Travel or transportation expenses for service in remote locations where an authorized Jenn-Air servicer is not available.
12. Removal or reinstallation of inaccessible appliances or built-in fixtures (i.e. trim, decorative panels, flooring, cabinetry, islands, countertops, drywall, etc.) that interfere with servicing, removal or replacement of the product.
13. Service or parts for appliances with original model/serial numbers removed, altered or not easily determined.

The cost of repair or replacement under these excluded circumstances shall be borne by the customer.

DISCLAIMER OF IMPLIED WARRANTIES

IMPLIED WARRANTIES, INCLUDING ANY IMPLIED WARRANTY OF MERCHANTABILITY OR IMPLIED WARRANTY OF FITNESS FOR A PARTICULAR PURPOSE, ARE LIMITED TO ONE YEAR OR THE SHORTEST PERIOD ALLOWED BY LAW. Some states and provinces do not allow limitations on the duration of implied warranties of merchantability or fitness, so this limitation may not apply to you. This warranty gives you specific legal rights, and you also may have other rights that vary from state to state or province to province.

DISCLAIMER OF REPRESENTATIONS OUTSIDE OF WARRANTY

Jenn-Air makes no representations about the quality, durability, or need for service or repair of this major appliance other than the representations contained in this warranty. If you want a longer or more comprehensive warranty than the limited warranty that comes with this major appliance, you should ask Jenn-Air or your retailer about buying an extended warranty.

LIMITATION OF REMEDIES; EXCLUSION OF INCIDENTAL AND CONSEQUENTIAL DAMAGES

YOUR SOLE AND EXCLUSIVE REMEDY UNDER THIS LIMITED WARRANTY SHALL BE PRODUCT REPAIR AS PROVIDED HEREIN. JENN-AIR SHALL NOT BE LIABLE FOR INCIDENTAL OR CONSEQUENTIAL DAMAGES. Some states and provinces do not allow the exclusion or limitation of incidental or consequential damages, so these limitations and exclusions may not apply to you. This warranty gives you specific legal rights, and you also may have other rights that vary from state to state or province to province.