

JENN-AIR® GAS COOKTOP TABLE DE CUISSON À GAZ JENN-AIR®

Use & Care Guide

For questions about features, operation/performance, parts, accessories, or service in the U.S.A., call:
1-800-JENNAIR (1-800-536-6247) or visit our website at **www.jennair.com**.

In Canada, call: **1-800-JENNAIR (1-800-536-6247)**, or visit our website at **www.jennair.ca**.

Guide d'utilisation et d'entretien

Au Canada, pour assistance, installation ou service, composez le **1-800-JENNAIR (1-800-536-6247)** ou visitez notre site web à **www.jennair.ca**.

Table of Contents/Table des matières2



W11032276A

TABLE OF CONTENTS

COOKTOP SAFETY	2
PARTS AND FEATURES	4
COOKTOP USE	5
Cooktop Controls.....	5
Sealed Surface Burners	5
Melt Cap.....	6
Surface Grates	6
Home Canning	7
Cookware	7
COOKTOP CARE	7
General Cleaning.....	7
TROUBLESHOOTING	8
ASSISTANCE OR SERVICE	9
In the U.S.A.	9
In Canada	9
Accessories.....	9
WARRANTY	10

TABLE DES MATIÈRES

SÉCURITÉ DE LA TABLE DE CUISSON	12
PIÈCES ET CARACTÉRISTIQUES	14
UTILISATION DE LA TABLE DE CUISSON	15
Commandes de la table de cuisson	15
Brûleurs de surface scellés.....	15
Chapeau pour faire fondre	16
Grilles de surface	16
Préparation de conserves à la maison	17
Ustensiles de cuisson	17
ENTRETIEN DE LA TABLE DE CUISSON	17
Nettoyage général.....	17
DÉPANNAGE	18
ASSISTANCE OU SERVICE	20
Aux É.U.	20
Au Canada.....	20
Accessoires	20
GARANTIE	21

COOKTOP SAFETY

Your safety and the safety of others are very important.

We have provided many important safety messages in this manual and on your appliance. Always read and obey all safety messages.



This is the safety alert symbol.

This symbol alerts you to potential hazards that can kill or hurt you and others.

All safety messages will follow the safety alert symbol and either the word “DANGER” or “WARNING.”

These words mean:

⚠ DANGER

You can be killed or seriously injured if you don't immediately follow instructions.

⚠ WARNING

You can be killed or seriously injured if you don't follow instructions.

All safety messages will tell you what the potential hazard is, tell you how to reduce the chance of injury, and tell you what can happen if the instructions are not followed.

WARNING: If the information in these instructions is not followed exactly, a fire or explosion may result causing property damage, personal injury or death.

- Do not store or use gasoline or other flammable vapors and liquids in the vicinity of this or any other appliance.
- **WHAT TO DO IF YOU SMELL GAS:**
 - Do not try to light any appliance.
 - Do not touch any electrical switch.
 - Do not use any phone in your building.
 - Immediately call your gas supplier from a neighbor's phone. Follow the gas supplier's instructions.
 - If you cannot reach your gas supplier, call the fire department.
- Installation and service must be performed by a qualified installer, service agency or the gas supplier.

WARNING: Gas leaks cannot always be detected by smell.

Gas suppliers recommend that you use a gas detector approved by UL or CSA.

For more information, contact your gas supplier.

If a gas leak is detected, follow the “What to do if you smell gas” instructions.

IMPORTANT SAFETY INSTRUCTIONS

WARNING: To reduce the risk of fire, electrical shock, injury to persons, or damage when using the cooktop, follow basic precautions, including the following:

- **WARNING:** NEVER use this appliance as a space heater to heat or warm the room. Doing so may result in carbon monoxide poisoning and overheating of the cooktop.
- **CAUTION:** Do not store items of interest to children in cabinets above the cooktop – children climbing on the cooktop to reach items could be seriously injured.
- Proper Installation – The cooktop, when installed, must be electrically grounded in accordance with local codes or, in the absence of local codes, with the *National Electrical Code, ANSI/NFPA70 or the Canadian Electrical Code, Part 1*. Be sure the cooktop is properly installed and grounded by a qualified technician.
- This cooktop is equipped with a three-prong grounding plug for your protection against shock hazard and should be plugged directly into a properly grounded receptacle. Do not cut or remove the grounding prong from this plug.
- Disconnect the electrical supply before servicing the cooktop.
- Injuries may result from the misuse of the cooktop such as stepping, leaning, or sitting on the top surface.
- Maintenance – Keep cooktop area clear and free from combustible materials, gasoline, and other flammable vapors and liquids.
- Storage on the cooktop – Flammable materials should not be stored on or near surface units.
- Top burner flame size should be adjusted so it does not extend beyond the edge of the cooking utensil.

SAVE THESE INSTRUCTIONS

State of California Proposition 65 Warnings:

WARNING: This product contains one or more chemicals known to the State of California to cause cancer.

WARNING: This product contains one or more chemicals known to the State of California to cause birth defects or other reproductive harm.

PARTS AND FEATURES

This manual covers different models. The cooktop you have purchased may have some or all of the items listed. The locations and appearances of the features shown here may not match those of your model.

30" (76.2 cm) and 36" (91.4 cm) Cooktops

IMPORTANT: See "Sealed Surface Burners" in the "Cooktop Use" section for proper burner base and cap positioning. Do not interchange burner caps.

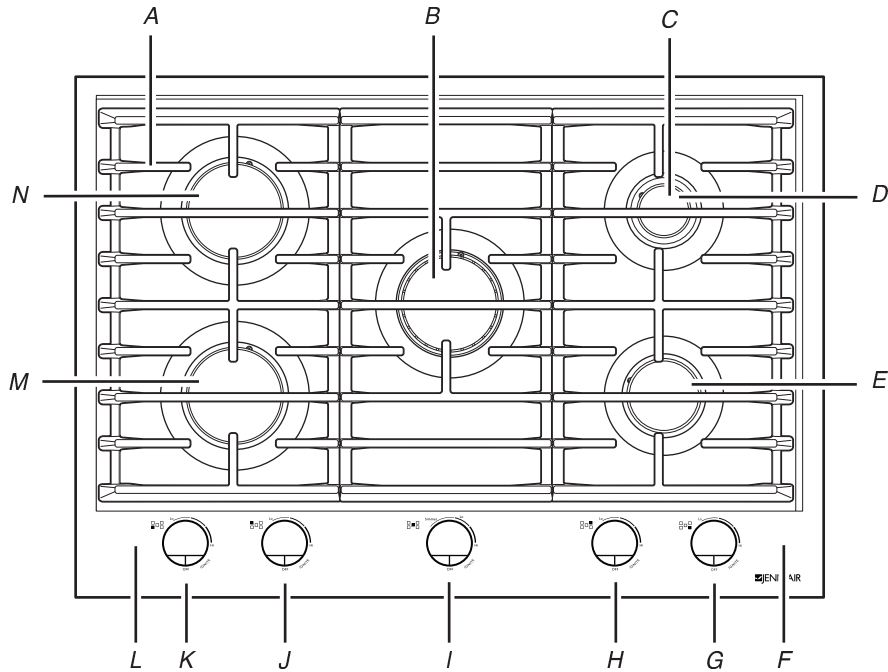

- | | | |
|-----------------------------------|--|---|
| A. Surface burner grate | E. Medium burner, 30" (76.2 cm)
Large burner, 36" (91.4 cm) | J. Lighted left rear control knob |
| B. Dual burner | F. Control panel | K. Lighted left front control knob |
| C. Surface burner cap
and base | G. Lighted right front control knob | L. Surface burner locator |
| D. Small burner | H. Lighted right rear control knob | M. Large burner |
| | I. Lighted center control knob | N. Large burner, 30" (76.2 cm)
X-Large burner, 36" (91.4 cm) |

COOKTOP USE

Cooktop Controls

⚠ WARNING



Fire Hazard

Do not let the burner flame extend beyond the edge of the pan.

Turn off all controls when not cooking.

Failure to follow these instructions can result in death or fire.

Electric igniters automatically light the surface burners when control knobs are turned to IGNITE and will automatically reignite if the flame is extinguished.

If a cross draft is present, the flame may be affected and some sparking may occur. This is normal.

Before setting a control knob, place filled cookware on the grate. Do not operate a burner using empty cookware or without cookware on the grate.

To Set:

1. Push in and turn knob counterclockwise to IGNITE.
2. Turn knob to anywhere between HI and LO. Use the following chart as a guide when setting heat levels.

SETTING	RECOMMENDED USE
HI	<ul style="list-style-type: none"> ■ Start food cooking. ■ Bring liquid to a boil. ■ Hold a rapid boil. ■ Quickly brown or sear food. ■ Fry chicken.
Medium Between HI and LO	<ul style="list-style-type: none"> ■ Maintain a slow boil. ■ Fry or sauté foods. ■ Cook soups, sauces, and gravies. ■ Stew or steam food.
LO	<ul style="list-style-type: none"> ■ Simmer.* ■ Keep food warm.
Simmer	<ul style="list-style-type: none"> ■ Simmer sauces.

* For a more delicate simmer, see the “Melt Cap” section.

REMEMBER: When cooktop is in use, the entire cooktop area may become hot.

Power failure

In case of power failure, the surface burners can be lit manually. Hold a lit match near a burner and turn knob counterclockwise to IGNITE. After burner lights, turn knob to setting.

IMPORTANT: Burner reignition feature does not work without power.

Sealed Surface Burners

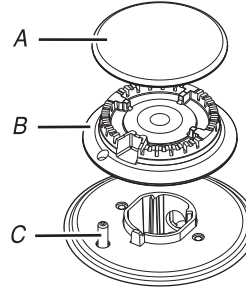

Standard Burner

- A. Cap
- B. Spreader
- C. Electrode

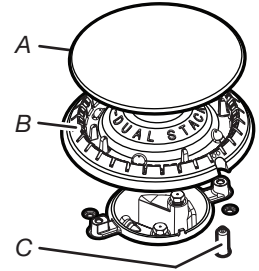

Dual Flame Burner

- A. Cap
- B. Spreader
- C. Electrode

Burner installation:

To install the burner base, insert the igniter electrode into the burner base hole or notch.

IMPORTANT: Do not obstruct the flow of combustion and ventilation air around the burner grate edges.

Burner cap: Always keep the burner cap in place when using a surface burner. A clean burner cap will help avoid poor ignition and uneven flames. Always clean the burner cap after a spillover and routinely remove and clean the caps according to the “General Cleaning” section.

Gas tube opening: Gas must flow freely throughout the gas tube opening for the burner to light properly. Keep this area free of soil and do not allow spills, food, cleaning agents, or any other material to enter the gas tube opening. Keep spillovers out of gas tube by always using a burner cap.

Burner ports: Check burner flames occasionally for proper size and shape. A good flame is blue in color, not yellow. Keep this area free of soil and do not allow spills, food, cleaning agents, or any other material to enter the burner ports.

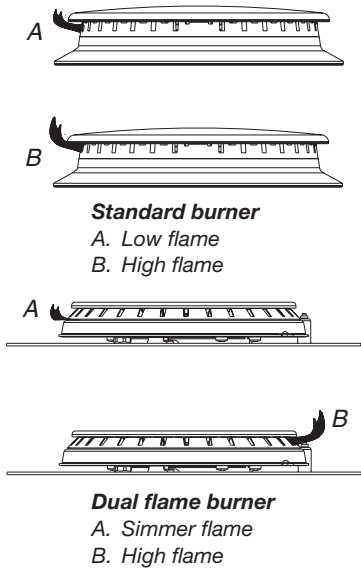

4. Turn on the burner. If the burner does not light, check burner cap and base alignment. See “Burner installation” in the “Sealed Surface Burners” section. If the burner still does not light, do not service the burner yourself. Contact a trained repair specialist.

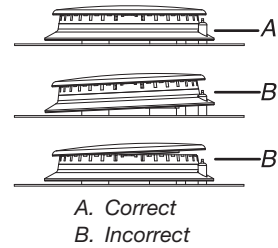

Melt Cap

For melting chocolate or butter or an even more delicate simmer, the melt cap can be used in place of the standard burner cap. The melt cap should only be used on the small burner (right rear). Remove the small burner cap and replace it with the larger melt cap for delicate simmering. For less delicate simmering, use the small cap.



To Clean:

IMPORTANT: Before cleaning, make sure all controls are OFF and cooktop is cool. Do not use oven cleaners, bleach, or rust removers.

1. Remove the burner cap from the burner base and clean according to the “General Cleaning” section.
2. Clean the gas tube opening with a damp cloth.
3. Replace burner bases and burner caps.

IMPORTANT:

- Be sure that the igniter electrode aligns with the slot or notch in the burner base. The igniter electrode is ceramic and could break during installation of the burner base.

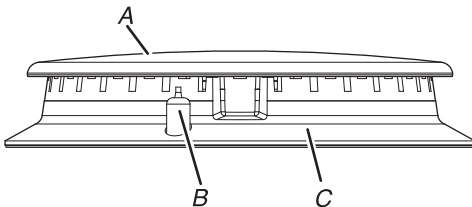

A. Burner cap
B. Igniter electrode
C. Burner base

- Be sure that the cap is properly positioned on the burner and that you have placed the cap on the correct burner. The ring on the bottom of the cap will align with the tabs on the burner. Do not interchange caps.

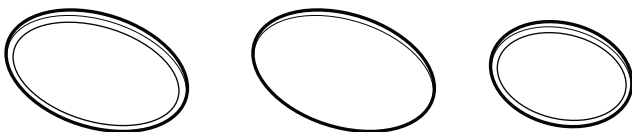

Dual flame burner cap Standard burner cap Small burner cap

Surface Grates

The surface grates are positioned correctly when the thick ribs form a frame around the outer edge and the thin ribs are located across the middle. All burners will be centered with the burner openings in the grates. See the following illustration.

NOTE: The end grates are different than the center grate. Do not use the end grate in the center grate position. End grates have a tab that prevents interchanging the center and end grates. Install the end grate first with the tab facing the center burner. Then install the center grate.

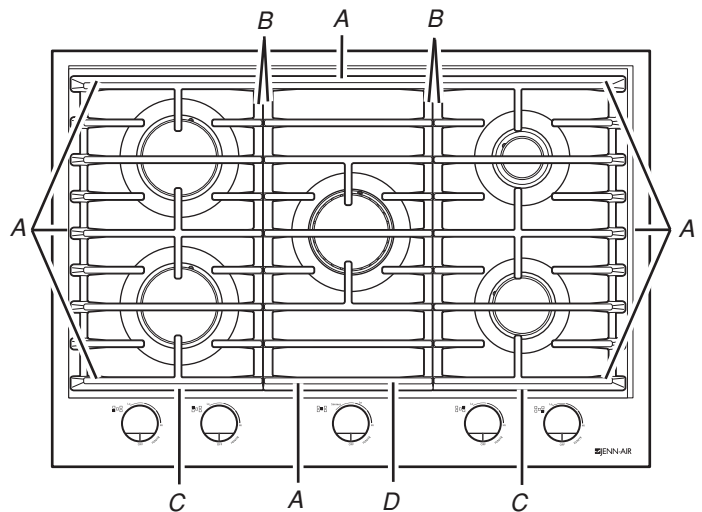

A. Thick ribs B. Thin ribs C. End grates D. Center grate

Home Canning

When canning for long periods, alternate the use of surface burners between batches. This allows time for the most recently used areas to cool.

- Center the canner on the grate above the burner.
 - Do not place canner on 2 surface burners at the same time.
 - For more information, contact your local agricultural department. Companies that manufacture home canning products can also offer assistance.
-

Cookware

IMPORTANT: Do not leave empty cookware on a hot surface cooking area, element, or surface burner.

Ideal cookware should have a flat bottom, straight sides, and a well-fitting lid and the material should be of medium-to-heavy thickness.

Rough finishes may scratch the cooktop. Aluminum and copper may be used as a core or base in cookware. However, when used as a base, they can leave permanent marks on the cooktop or grates.

Cookware material is a factor in how quickly and evenly heat is transferred, which affects cooking results. A nonstick finish has the same characteristics as its base material.

For example, aluminum cookware with a nonstick finish will take on the properties of aluminum.

Use the following chart as a guide for cookware material characteristics.

Cookware	Characteristics
Aluminum	<ul style="list-style-type: none">■ Heats quickly and evenly.■ Suitable for all types of cooking.■ Medium or heavy thickness is best for most cooking tasks.
Cast iron	<ul style="list-style-type: none">■ Heats slowly and evenly.■ Good for browning and frying.■ Maintains heat for slow cooking.
Ceramic or Ceramic glass	<ul style="list-style-type: none">■ Follow manufacturer's instructions.■ Heats slowly, but unevenly.■ Ideal results on low-to-medium heat settings.
Copper	<ul style="list-style-type: none">■ Heats very quickly and evenly.
Earthenware	<ul style="list-style-type: none">■ Follow manufacturer's instructions.■ Use on low heat settings.
Porcelain enamel-onsteel or cast iron	<ul style="list-style-type: none">■ See stainless steel or cast iron.
Stainless steel	<ul style="list-style-type: none">■ Heats quickly, but unevenly.■ A core or base of aluminum or copper on stainless steel provides even heating.

COOKTOP CARE

General Cleaning

IMPORTANT: Before cleaning, make sure all controls are OFF and the cooktop is cool. Always follow the label instructions on cleaning products.

Soap, water and a soft cloth or sponge are suggested first unless otherwise noted.

STAINLESS STEEL

To avoid damage to stainless steel surfaces, do not use soap-filled scouring pads, abrasive cleaners, cooktop cleaner, steelwool pads, gritty washcloths, abrasive paper towels, or stainless steel brightener.

Rub in the direction of the grain to avoid damaging.

Cleaning Method:

- affresh® Stainless Steel Cleaner Part Number W10355016 (not included):
See the "Assistance or Service" section to order.
 - Liquid detergent or all-purpose cleaner:
Rinse with clean water and dry with a soft, lint-free cloth.
 - Vinegar for hard water spots
-

COOKTOP CONTROLS

To avoid damage to the cooktop controls, do not use steel wool, abrasive cleansers, or oven cleaner. Do not spray cleaners in the control area when the knobs are removed. Apply spray cleaners to a soft cloth or sponge, not directly on the control area.

To avoid damage, do not soak the knobs.

When replacing the knobs, make sure the knobs are in the Off position.

On some models, do not remove seals under the knobs.

Cleaning Method:

- Soap and water:
Pull the knobs straight away from the control panel to remove them.
-

CONTROL PANEL

To avoid damage to the control panel, do not use abrasive cleaners, steel-wool pads, gritty washcloths, or abrasive paper towels.

Cleaning Method:

- affresh® Kitchen and Appliance Cleaner Part Number W10355010 (not included):
See the "Assistance or Service" section to order.
-

PORCELAIN-COATED GRATES AND CAPS

Food spills containing acids, such as vinegar and tomato, should be cleaned as soon as the cooktop, grates, and caps are cool. These spills may affect the finish.

To avoid chipping, do not bang the grates and caps against each other or hard surfaces such as cast iron cookware.

Do not reassemble the caps on burners while wet.

Cleaning Method:

- Nonabrasive plastic scrubbing pad and mildly abrasive cleanser:
Clean as soon as the cooktop, grates, and caps are cool.
- Dishwasher (grates only, not caps):
Use the most aggressive cycle.
- Gas Grate and Drip Pan Cleaner Part Number 31617 (not included):
See the “Assistance or Service” section to order.

SURFACE BURNERS AND ELECTRONIC IGNITER

Surface Burners

See the “Sealed Surface Burners” section.

Electronic Igniter

Cleaning Method:

- affresh® Kitchen and Appliance Cleaner Part Number W10355010 (not included):
Clean the ceramic post with a cotton swab.
See the “Assistance or Service” section to order.

TROUBLESHOOTING

First try the solutions suggested here. If you need further assistance or more recommendations that may help you avoid a service call, refer to the warranty page in this manual and scan the code there with your mobile device, or visit <http://jennair.custhelp.com>. In Canada, visit <http://www.jennair.ca>.

Contact us by mail with any questions or concerns at the address below:

In the U.S.A.:

Jenn-Air Brand Home Appliances
Customer eXperience Center
553 Benson Road
Benton Harbor, MI 49022-2692

In Canada:

Jenn-Air Brand Home Appliances
Customer eXperience Centre
200 - 6750 Century Ave.
Mississauga, Ontario L5N 0B7

Please include a daytime phone number in your correspondence.

⚠ WARNING



Electrical Shock Hazard

Plug into a grounded 3 prong outlet.

Do not remove ground prong.

Do not use an adapter.

Do not use an extension cord.

Failure to follow these instructions can result in death, fire, or electrical shock.

Problem	Possible Causes and/or Solutions
Nothing will operate	Is the power supply cord unplugged? Plug into a grounded 3 prong outlet. Has a household fuse blown, or has a circuit breaker tripped? Replace the fuse or reset the circuit breaker. If the problem continues, call an electrician.
Surface burners will not operate	Is this the first time the surface burners have been used? Turn on any one of the surface burner knobs to release air from the gas lines. Is the control knob set correctly? Push the knob in before turning it to a setting. Are the burner ports clogged? See the “Sealed Surface Burners” section.
Surface burner flames are uneven, yellow, and/or noisy	Are the burner ports clogged? See the “Sealed Surface Burners” section. Are the burner caps positioned properly? See the “Sealed Surface Burners” section. Is propane gas being used? The cooktop may have been converted improperly. Contact a service technician or see the “Assistance or Service” section.
Surface burner makes popping noises	Is the burner wet? Let it dry.

Problem	Possible Causes and/or Solutions
Continuous sparking of igniter	<p>Is a cross draft drawing the flame away from the igniter? This is normal when a cross draft is present.</p> <p>Is the power supply cord properly grounded/polarized? See the Installation Instructions.</p> <p>Is the burner base and/or cap positioned properly? See “To Clean” in the “Sealed Surface Burners” section.</p> <p>Has the control area been cleaned? Excessive use of liquid cleaners in the control knob area may cause continuous sparking. Let it dry.</p>
Excessive heat around cookware on cooktop	<p>Is the cookware the proper size? Use cookware about the same size as the surface cooking area, element, or surface burner. Cookware should not extend more than ½" (1.3 cm) outside the cooking area.</p>
Cooktop cooking results not what expected	<p>Is the proper cookware being used? See the “Cookware” section.</p> <p>Is the control knob set to the proper heat level? See the “Cooktop Controls” section.</p> <p>Is the cooktop level? Level the cooktop. See the Installation Instructions.</p>

ASSISTANCE OR SERVICE

If you need service

Please refer to the warranty page in this manual.

If you need replacement parts

If you need to order replacement parts, we recommend that you use only factory specified parts. These factory specified parts will fit right and work right because they are made with the same precision used to build every new JENN-AIR® appliance.

To locate factory specified parts in your area, call us or your nearest JENN-AIR designated service center.

In the U.S.A.

Call the Jenn-Air Customer eXperience Center toll free:
1-800-JENNAIR (1-800-536-6247)

Our consultants provide assistance with:

- Scheduling of service. Jenn-Air® appliances designated service technicians are trained to fulfill the product warranty and provide after-warranty service anywhere in the United States.
- Features and specifications on our full line of appliances.
- Referrals to local Jenn-Air® appliance dealers.
- Installation information.
- Use and maintenance procedures.
- Accessory and repair parts sales.
- Specialized customer assistance (Spanish speaking, hearing impaired, limited vision, etc.).
To locate the Jenn-Air designated service company in your area, you can also look in your telephone directory Yellow Pages.

For further assistance:

If you need further assistance, you can write to Jenn-Air with any questions or concerns at:

Jenn-Air Brand Home Appliances
Customer eXperience Center
553 Benson Road
Benton Harbor, MI 49022-2692
Web address: www.jennair.com

Please include a daytime phone number in your correspondence.

In Canada

Call the Jenn-Air Customer eXperience Centre toll free:
1-800-JENNAIR (1-800-536-6247)

Our consultants provide assistance with:

- Scheduling of service. Jenn-Air® appliances designated service technicians are trained to fulfill the product warranty and provide after-warranty service anywhere in Canada.
- Features and specifications on our full line of appliances.
- Referrals to local Jenn-Air® appliance dealers.
- Use and maintenance procedures.
- Accessory and repair parts sales.

For further assistance:

If you need further assistance, you can write to:

Jenn-Air Brand Home Appliances
Customer eXperience Centre
200 - 6750 Century Ave.
Mississauga, Ontario L5N 0B7
Web address: www.jennair.ca

Please include a daytime phone number in your correspondence.

Accessories

To order accessories, call the Jenn-Air Customer eXperience Center toll free at **1-800-JENNAIR (1-800-536-6247)** and follow the menu prompts. Or visit our website at www.jennair.com and click on “Accessories.”

affresh® Stainless Steel Cleaner

Order Part Number W10355016

Gas Grate and Drip Pan Cleaner

Order Part Number 31617

affresh® Kitchen and Appliance Cleaner

Order Part Number W10355010

JENN-AIR® COOKING LIMITED WARRANTY

ATTACH YOUR RECEIPT HERE. PROOF OF PURCHASE IS REQUIRED TO OBTAIN WARRANTY SERVICE.

Please have the following information available when you call the Customer eXperience Center:

- Name, address and telephone number
- Model number and serial number
- A clear, detailed description of the problem
- Proof of purchase including dealer or retailer name and address

IF YOU NEED SERVICE:

1. Before contacting us to arrange service, please determine whether your product requires repair. Some questions can be addressed without service. Please take a few minutes to review the Troubleshooting or Problem Solver section of the Use and Care Guide, scan the QR code on the right to access additional resources, or visit <https://jennair.custhelp.com>.
2. All warranty service is provided exclusively by our authorized Jenn-Air Service Providers. In the U.S. and Canada, direct all requests for warranty service to:

Jenn-Air Customer eXperience Center
1-800-JENNAIR (1-800-536-6247).



<https://jennair.custhelp.com>

If outside the 50 United States or Canada, contact your authorized Jenn-Air dealer to determine whether another warranty applies.

FIVE YEAR LIMITED WARRANTY

WHAT IS COVERED

TWO YEAR LIMITED WARRANTY (PARTS & LABOR)

For two years from the date of purchase, when this major appliance is installed, operated and maintained according to instructions attached to or furnished with the product, Jenn-Air brand of Whirlpool Corporation or Whirlpool Canada, LP (hereafter "Jenn-Air") will pay for factory specified replacement parts and repair labor to correct defects in materials or workmanship that existed when this major appliance was purchased or, at its sole discretion replace the product. In the event of product replacement, your appliance will be warranted for the remaining term of the original unit's warranty period.

THIRD THROUGH FIFTH YEAR LIMITED WARRANTY (CERTAIN COMPONENT PARTS ONLY - LABOR NOT INCLUDED)

In the third through fifth years from the date of original purchase, when this major appliance is installed, operated and maintained according to instructions attached to or furnished with the product, Jenn-Air will pay for factory specified parts for the following components to correct non-cosmetic defects in materials or workmanship in these parts that prevent function of this major appliance and that existed when this major appliance was purchased. This is a limited 5-year warranty on the below named parts only and does not include repair labor.

- Electric element
- Touch Pad and microprocessor
- Glass ceramic cooktop: if due to thermal breakage
- Electronic controls
- Magnetron tube
- Sealed gas burners

YOUR SOLE AND EXCLUSIVE REMEDY UNDER THIS LIMITED WARRANTY SHALL BE PRODUCT REPAIR AS PROVIDED HEREIN. Service must be provided by a Jenn-Air designated service company. This limited warranty is valid only in the United States or Canada and applies only when the major appliance is used in the country in which it was purchased. This limited warranty is effective from the date of original consumer purchase. Proof of original purchase date is required to obtain service under this limited warranty.

WHAT IS NOT COVERED

1. Commercial, non-residential, multiple-family use, or use inconsistent with published user, operator or installation instructions.
2. In-home instruction on how to use your product.
3. Service to correct improper product maintenance or installation, installation not in accordance with electrical or plumbing codes or correction of household electrical or plumbing (i.e. house wiring, fuses or water inlet hoses).
4. Consumable parts (i.e. light bulbs, batteries, air or water filters, preservation solutions, etc.).
5. Defects or damage caused by the use of non-genuine Jenn-Air parts or accessories.
6. Conversion of products from natural gas or L.P. gas.
7. Damage from accident, misuse, abuse, fire, floods, acts of God or use with products not approved by Jenn-Air.
8. Repairs to parts or systems to correct product damage or defects caused by unauthorized service, alteration or modification of the appliance.
9. Cosmetic damage including scratches, dents, chips, and other damage to the appliance finishes unless such damage results from defects in materials and workmanship and is reported to Jenn-Air within 30 days.
10. Discoloration, rust or oxidation of surfaces resulting from caustic or corrosive environments including but not limited to high salt concentrations, high moisture or humidity or exposure to chemicals.
11. Food or medicine loss due to product failure.
12. Pick-up or delivery. This product is intended for in-home repair.
13. Travel or transportation expenses for service in remote locations where an authorized Jenn-Air servicer is not available.
14. Removal or reinstallation of inaccessible appliances or built-in fixtures (i.e. trim, decorative panels, flooring, cabinetry, islands, countertops, drywall, etc.) that interfere with servicing, removal or replacement of the product.
15. Service or parts for appliances with original model/serial numbers removed, altered or not easily determined.

The cost of repair or replacement under these excluded circumstances shall be borne by the customer.

DISCLAIMER OF IMPLIED WARRANTIES

IMPLIED WARRANTIES, INCLUDING ANY IMPLIED WARRANTY OF MERCHANTABILITY OR IMPLIED WARRANTY OF FITNESS FOR A PARTICULAR PURPOSE, ARE LIMITED TO ONE YEAR OR THE SHORTEST PERIOD ALLOWED BY LAW. Some states and provinces do not allow limitations on the duration of implied warranties of merchantability or fitness, so this limitation may not apply to you. This warranty gives you specific legal rights, and you also may have other rights that vary from state to state or province to province.

DISCLAIMER OF REPRESENTATIONS OUTSIDE OF WARRANTY

Jenn-Air makes no representations about the quality, durability, or need for service or repair of this major appliance other than the representations contained in this warranty. If you want a longer or more comprehensive warranty than the limited warranty that comes with this major appliance, you should ask Jenn-Air or your retailer about buying an extended warranty.

LIMITATION OF REMEDIES; EXCLUSION OF INCIDENTAL AND CONSEQUENTIAL DAMAGES

YOUR SOLE AND EXCLUSIVE REMEDY UNDER THIS LIMITED WARRANTY SHALL BE PRODUCT REPAIR AS PROVIDED HEREIN. JENN-AIR SHALL NOT BE LIABLE FOR INCIDENTAL OR CONSEQUENTIAL DAMAGES. Some states and provinces do not allow the exclusion or limitation of incidental or consequential damages, so these limitations and exclusions may not apply to you. This warranty gives you specific legal rights, and you also may have other rights that vary from state to state or province to province.

Notes