



Designer Series Refrigeration

Use and Care Guide

CLEANING, MAINTENANCE,
AND MORE



Contents

3	Designer Series Refrigeration
4	Safety Precautions
6	Designer Series Features
8	Touch Controls
10	Storage
14	Product Operation
20	Food Preservation
22	Care Recommendations
23	Troubleshooting
26	Sub-Zero Warranty

Customer Care

The model and serial number are printed on the enclosed product registration card. Both numbers are also listed on the product rating plate. Refer to pages 6–7 for rating plate location. For warranty purposes, you will also need the date of installation and name of your authorized Sub-Zero dealer. Record this information below for future reference.

SERVICE INFORMATION

Model Number	_____
Serial Number	_____
Date of Installation	_____
Certified Service Name	_____
Certified Service Number	_____
Authorized Dealer	_____
Dealer Number	_____

If your product ever needs attention, be sure to use a Sub-Zero Factory Certified Service provider recommended by our Customer Care Center, or select one from our list of providers available at subzero.com/locator. All Factory Certified Service providers are carefully selected and thoroughly trained by us.

Important Note

To ensure this product is installed and operated as safely and efficiently as possible, take note of the following types of highlighted information throughout this guide:

IMPORTANT NOTE highlights information that is especially important.

⚠ CAUTION

Indicates a situation where minor injury or product damage may occur if instructions are not followed.

⚠ WARNING

States a hazard that may cause serious injury or death if precautions are not followed.

IMPORTANT NOTE: Throughout this guide, dimensions in parentheses are millimeters unless otherwise specified.

IMPORTANT INSTRUCTIONS

▲ WARNING

Do not store explosive substances such as aerosol cans with a flammable propellant in this appliance.

▲ WARNING

Keep ventilation openings, in the appliance enclosure or in the built-in structure, clear of obstruction.

▲ WARNING

Do not use mechanical devices or other means to accelerate the defrosting process, other than those recommended by the manufacturer.

▲ WARNING

Do not expose this appliance to rain.

▲ WARNING

This appliance is only intended for residential use.

▲ WARNING

- This appliance contains flammable refrigerant and must be handled, installed, serviced, and decommissioned by authorized personnel. Once decommissioned, consult local authorities for disposal instructions.
- To minimize the risk of ignition due to improper installation, replacement parts, or service procedures, only refrigeration technicians with flammable refrigerant training who are aware of the dangers of dealing with high voltage electricity and refrigerant under pressure are allowed to work on this equipment.
- Do not damage the refrigeration circuit when installing, maintaining, or servicing the unit.
-  This symbol indicates risk of fire/flammable materials.

▲ CAUTION

Incorporated ice makers must be installed by the manufacturer or its service agent.

▲ WARNING

Do not use electrical appliances inside the food storage compartments of the appliance, unless they are of the type recommended by the manufacturer.

IMPORTANT INSTRUCTIONS

▲ WARNING

This appliance is not intended for use by persons (including children) with reduced physical, sensory or mental capabilities, or lack of experience and knowledge, unless they have been given supervision or instruction concerning use of the appliance by a person responsible for their safety. Children should be supervised to ensure they do not play with the appliance.

▲ WARNING

DANGER: Risk of child entrapment. Before you throw away your old refrigerator or freezer:

- Take off the doors.
- Leave the shelves and drawer dividers in place so that children may not easily climb inside.

▲ WARNING

PROPOSITION 65 FOR CALIFORNIA RESIDENTS

Cancer and Reproductive Harm—
www.P65Warnings.ca.gov

This appliance is intended to be used in household and similar applications such as:

- staff kitchen areas in shops, offices, and other working environments
- farm houses and by clients in hotels, motels, and other residential type environments
- bed and breakfast type environments
- catering and similar non-retail applications

Designer Series Features

FEATURES

1	Product Rating Plate
2	Touch Control Panel
3	Freshness Cards
4	Adjustable Door Shelves
5	Flip-Up Dairy Compartment
6	Refrigerator Shelves
7	Refrigerator Storage Drawers
8	Freezer Shelves
9	Freezer Storage Drawers
10	Removable Ice Bin
11	Air Purification System
12	Water Filtration System
13	Automatic Ice Maker (ice maker models)
14	Internal Water Dispenser (dispenser models)
15	Condenser (behind grille)

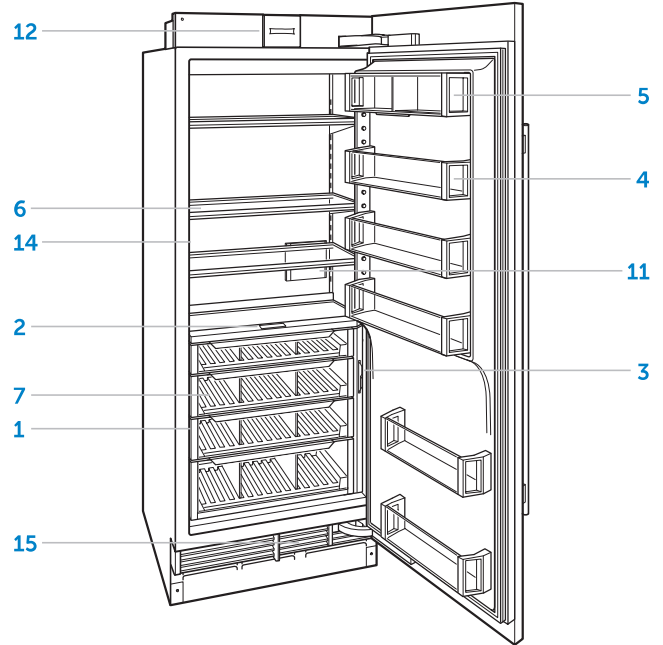

Column all refrigerator

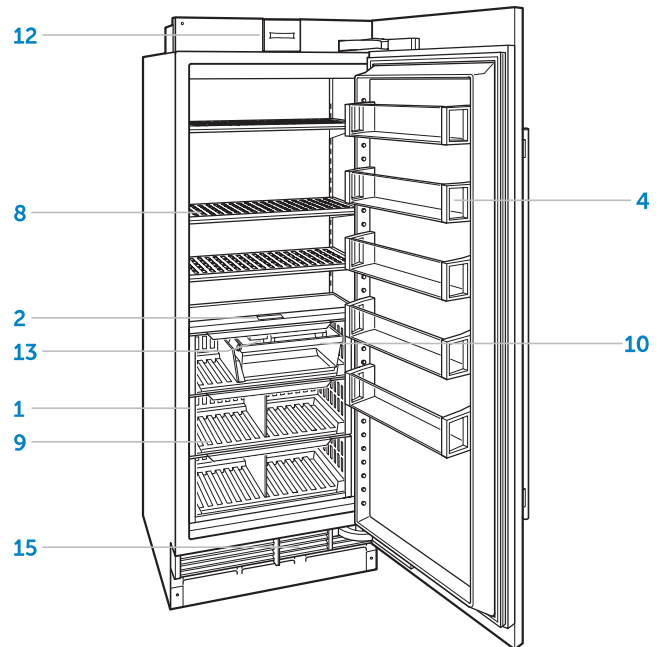

Column all freezer

Designer Series Features

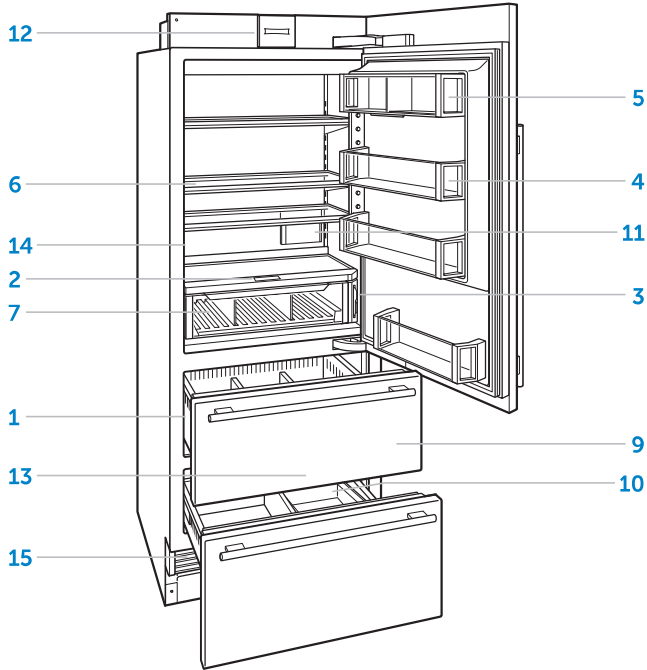

Tall combination

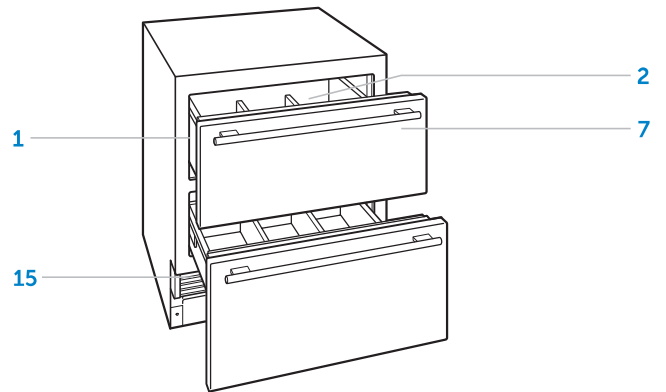

Drawer all refrigerator

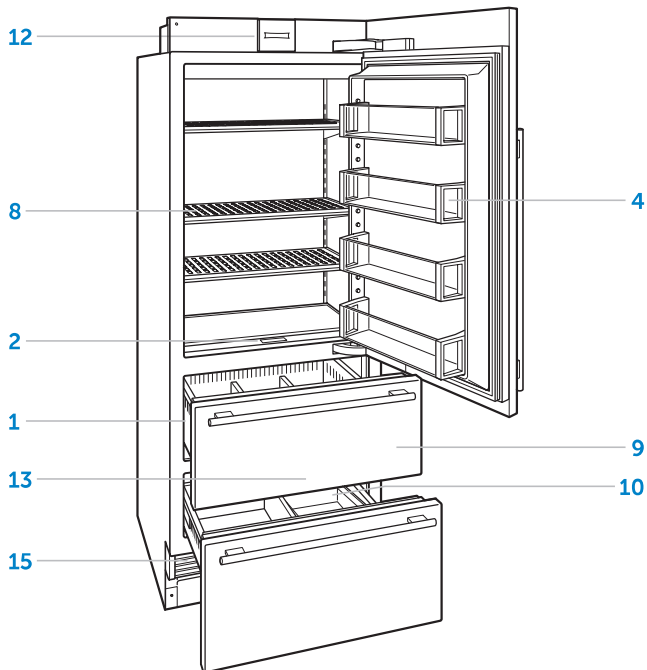

Tall all freezer

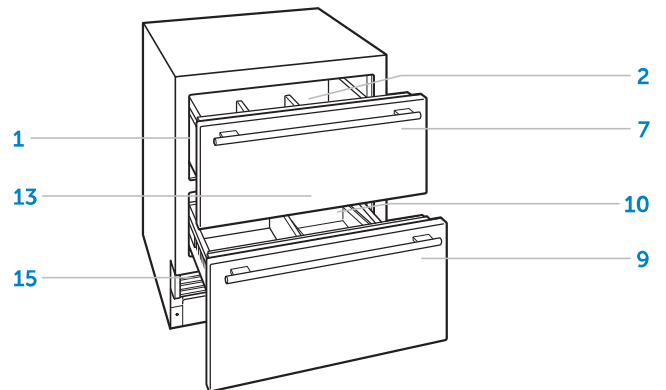

Drawer combination

Touch Control Panel

For initial start-up, touch and hold ⓘ on the control panel for 2 seconds.

The recommended temperatures are preset at 0°F (-18°C) for a freezer and 38°F (3°C) for a refrigerator. The temperatures are adjustable in one-degree increments. The combination model has two temperature zones.

To adjust temperature:

- 1 Touch the temperature to be adjusted.
- 2 Touch + or – until the desired temperature is displayed. Refer to the illustration below.

To adjust additional settings, touch ⚙ on the control panel. Refer to the illustration below.



















Dual-zone home screen



Single-zone home screen

SETTINGS

	Adjust refrigerator drawer temperature and humidity
	Turn ice maker and max ice on or off
	Turn air purifier on or off
	Adjust soft on lighting and accent lighting (if applicable)
	Turn night mode on or off
	Turn the dispenser on or off
	Turn door alarm on or off and adjust duration
	Adjust door alarm volume and tone
	Turn water filter reminder on or off
	Turn connect on or off (if applicable)
	Turn the unit on or off
	Turn Sabbath on or off
	Adjust temperature units
	Select language
	System information
	View troubleshooting and service information

Connect This Appliance

Connect this appliance to remotely monitor and control it. Connecting requires a wireless router, an Internet connection with a network name and password, and a compatible mobile device. There is no limit to the number of appliances you can connect to an account. Connect products from multiple homes to the same account. Connecting appliances is optional.

Connect today to:

- Receive alerts, status updates, and routine maintenance notifications.
- Streamline everyday tasks with the help of remote controls and voice commands.
- Quickly access user manuals and cleaning and maintenance tips.

To connect:

- 1 Download the free Sub-Zero Group Owner's App from the Apple App Store or Google Play.
- 2 With Bluetooth® enabled on the device, stand within a few feet of the appliance, open the app, and follow the on-screen instructions.
- 3 Log in or create an account.
- 4 Tap Add An Appliance or tap + in upper right of the screen to add appliances. To identify which appliance to pair, open the appliance door.
- 5 Tap + next to the appliance to select it. If identical appliances appear, follow the additional step on the screen to identify which appliance to pair.
- 6 Tap Pair Via Bluetooth®. Wait for setup to complete, then tap Set Up Your Appliance For Pairing.
- 7 Tap Choose a Network on the Connect Your Appliance to Wi-Fi screen.
- 8 Select the home Wi-Fi network and enter the network password.
- 9 Tap Turn on Notifications to allow notifications about the appliance (for example, door left ajar).
- 10 Tap Done on the Success screen to complete the setup.

Dual Refrigeration®

This Sub-Zero features a unique Dual Refrigeration® system to keep food fresher longer.

With the Sub-Zero Dual Refrigeration® system, individual refrigerator and freezer systems have been designed to maintain accurate, consistent temperatures and proper humidity levels for longer food life expectancy. Dual Refrigeration® eliminates transfer of fresh food odors to frozen food and ice and does not freeze the moisture out of the air in the fresh food section.

Refrigerator Storage

ADJUSTABLE DOOR SHELVES

To reposition a door shelf or dairy compartment:

- 1 To remove, lift the shelf from the bottom and slide out. Refer to the illustration below.
- 2 To install, place in the desired position and slide the shelf down onto the guides.

IMPORTANT NOTE: If the door opening is limited to 90°, door shelves may need to be removed before removing a storage drawer or glass shelf.

FLIP-UP DAIRY COMPARTMENT

The bottom of the dairy compartment rotates upward to accommodate taller items below. For models without vertical dividers in the compartment, the entire bottom rotates upward. For models with a vertical divider, one section rotates upward. Refer to the illustration below.

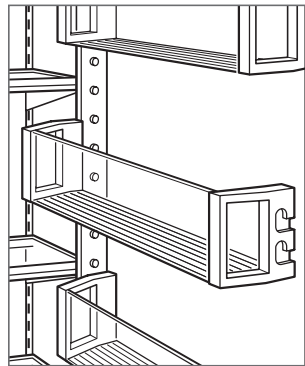

Door shelf removal

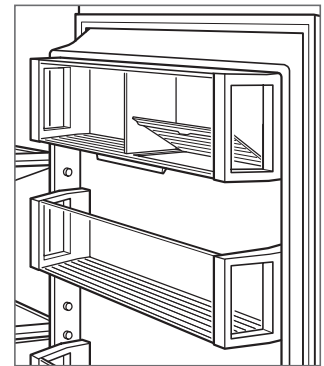

Flip up dairy compartment

Refrigerator Storage

GLASS SHELVES

To reposition a glass shelf:

- 1 To remove, tilt the shelf up, then lift up and out. Refer to the illustration below.
- 2 To install, insert the shelf in the tracks along the back wall, then lower the front until it locks into position.

IMPORTANT NOTE: Use care when handling glass shelves to prevent breakage or scratching the interior.

⚠ CAUTION

Glass shelves should warm to room temperature before immersing in warm water.

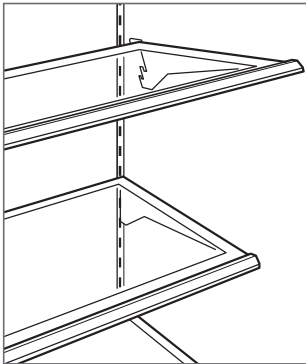

Glass shelf removal

REFRIGERATOR STORAGE DRAWERS

To remove and install a refrigerator drawer:

- 1 To remove, pull the drawer open until it stops.
- 2 Lift the front of the drawer slightly and pull straight out. Refer to the illustration below.
- 3 To install, pull the drawer carrier out and align the bottom of the drawer with the carrier.
- 4 Slide the drawer back into position.

To reposition a refrigerator drawer divider:

- 1 To remove, pull the divider straight up.
- 2 To install, align tabs on the divider with notches in the drawer and push down.

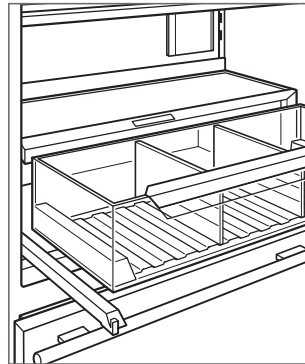

Refrigerator drawer removal

Storage Drawers

CRISPER COVER

The crisper cover in the upper storage drawer can be slid closed, left open, or removed.

To remove the crisper cover:

- 1 Pull the upper storage drawer all the way out.
- 2 Raise the front edge of the crisper cover and pull it forward and out of the drawer. Refer to the illustration below.

DRAWER DIVIDERS

To reposition a drawer divider:

- 1 To remove a short divider, flex the long divider slightly, then pull upward. Refer to the illustration below.
- 2 For 36" wide drawer models only, one long divider is adjustable. To remove a long divider, all short dividers must be removed. Pull the long divider up until it stops, rotate counterclockwise, then pull upward.
- 3 To install a long divider, align the grooves with the drawer tabs, rotate clockwise, then slide down.
- 4 To install a short divider, position as desired, then slide down.

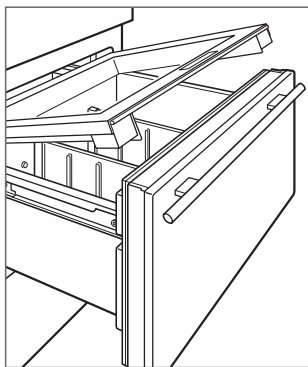

Crisper cover

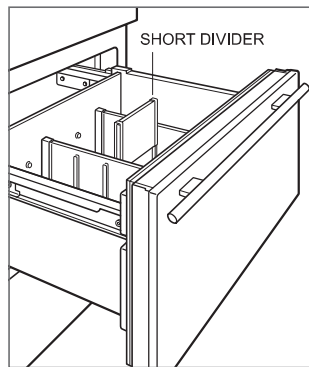

Drawer dividers

DRAWER REMOVAL

To remove/install a storage drawer:

- 1 To remove, pull the drawer open until it stops. Raise the front of the drawer slightly and pull straight out. Refer to the illustration below.
- 2 To install, raise the front of drawer and place onto the slides. Align the back of the drawer with hooks on the slide, then align the white pegs at the front of the slide with holes at the front of the drawer.

IMPORTANT NOTE: For drawer models, the upper drawer has a control cable that must be disconnected before removing the drawer. Refer to the illustration below.

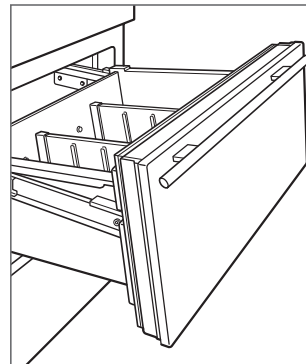

Drawer removal

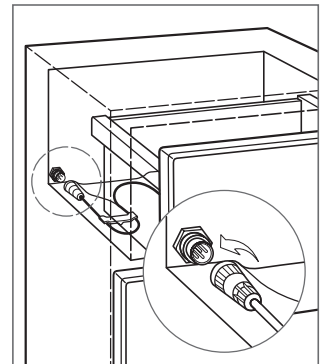

Control cable (drawer model)

Freezer Storage

FREEZER STORAGE DRAWERS

To remove a freezer drawer:

- 1 Pull the drawer open until it stops.
- 2 Locate the two plastic tabs at the front of the drawer behind the bottom corners.
- 3 Pull the tabs forward, then lift up and out. Refer to the illustrations below.

If the door opening is limited to 90°, the top drawer must be removed before removing the middle or lower drawer.

To install a freezer drawer:

- 1 Push the drawer slides in.
- 2 Align the drawer with the slides and push back until it stops.
- 3 Press down on the front of the drawer to engage the slides.

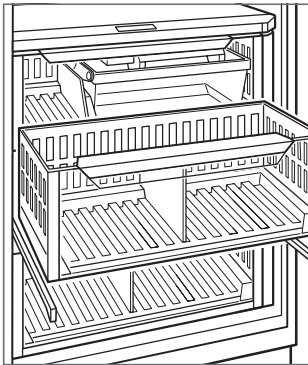

Column freezer drawer

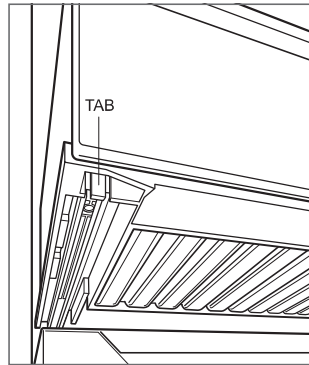

Freezer drawer tab

ICE BIN

To remove the ice bin (column model):

- 1 Pull the freezer drawer open until it stops.
- 2 Lift the ice bin out. Refer to the illustration below.

To remove the ice bin (tall and drawer models):

- 1 Pull the freezer drawer open until it stops.
- 2 Lift the ice bin out. Refer to the illustration below.

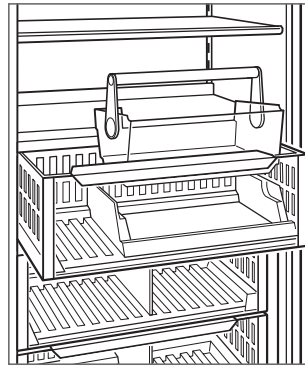

Column ice bin

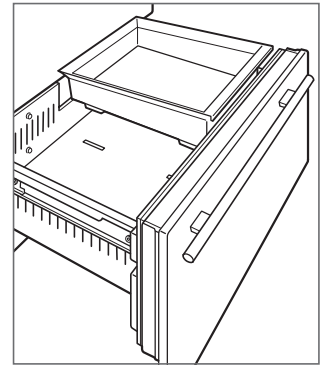

Tall and drawer ice bin

Temperature



TEMPERATURE CONTROL

To optimize food preservation, the refrigerator drawer temperature is adjustable automatically or manually. All drawers are set to the same temperature and cannot be adjusted individually.

Auto Mode—automatically adjusts the refrigerator drawer temperature 2° below the refrigerator set temperature, but cannot go below 34°F (1°C).

Manual Mode—manually adjust the refrigerator drawer up to 2° above or below the refrigerator setpoint, but cannot go below 34°F (1°C) or above 42°F (6°C).

To adjust temperature:



- 1 Touch .
- 2 Touch .
- 3 Touch "A" or "M" to toggle between modes.
- 4 Touch + or – to adjust the temperature manually.

Humidity

HUMIDITY CONTROL

Some foods, particularly vegetables, require enhanced levels of humidity to maximize freshness. The refrigerator drawer humidity level is adjustable. Select "Enhanced" to make sure produce lasts to its full potential. All drawers are set to the same level and cannot be adjusted individually.

To adjust humidity:

- 1 Touch .
- 2 Touch .
- 3 Touch  to toggle between settings.

Air Purification System

Many fresh foods emit ethylene gas, a naturally-occurring compound that hastens food ripening and spoilage. If your unit is equipped with an air purification system, the cartridge has been factory installed and is located on the back wall of the refrigerator.

To turn on air purification, touch  on the options screen.

⚠ CAUTION

The air purification system complies with applicable federal requirements regarding incidental exposure to ultraviolet light. Lamp contains mercury. Manage in accordance with disposal laws. Visit earth911.com or call 800-222-7820.

AIR PURIFICATION CARTRIDGE

The air purification cartridge lasts approximately one year. "Snooze/Refresh" appears on the control panel when the cartridge needs to be replaced. Touch "Snooze" to delay the reminder for 24 hours or until the cartridge can be replaced.

Replacement Sub-Zero air purification cartridges can be ordered online at subzero.com/store. For questions, contact Sub-Zero Customer Care at 800-222-7820.

To replace the air purification cartridge:

- 1 To access the air purification cartridge, slide the door to the left.
- 2 Grasp the black cover from the top and rotate downward. The cartridge pops out and can be removed. Refer to the illustration below.
- 3 Remove the new cartridge from packaging and insert with the connector pointing downward.
- 4 Close the black cover, then slide the door to the right.
- 5 Follow the instructions on the control panel. The cartridge life cycle resets for approximately one year.

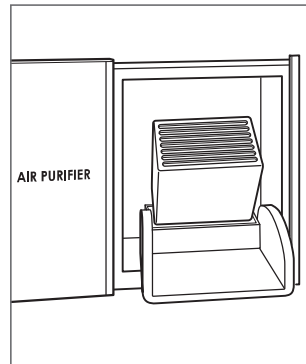

Air purification cartridge

Water Filtration System

The water filtration system supplies filtered water to the ice maker and water dispenser (dispenser models) to produce great-tasting water and ice.

IMPORTANT NOTE: When using the water filtration system for the first time and after filter replacement, it is necessary to clear any air from the system and allow the filter to assist in cleaning the water lines. For non-dispenser models, discard the first two full containers of ice. For dispenser models, dispense several glasses of water for a period of two minutes.

If the water filtration system will not be used, it can be placed in water filter bypass mode by removing the filter.

"Snooze/Refresh" appears on the control panel when the filter needs to be replaced. Touch "Snooze" to delay the reminder for 24 hours or until the filter can be replaced.

Replacement Sub-Zero water filters can be ordered online at subzero.com/store. For questions, contact Sub-Zero Customer Care at 800-222-7820.

To replace the water filter:

- 1 To access the water filter, pull out on the bottom edge of the access door and rotate upward. Refer to the illustration below.
- 2 To remove the old filter, rotate counterclockwise one-quarter turn, then pull out. It is normal for a small amount of water to drip when the filter is removed. It should be wiped up with a paper towel or cloth.
- 3 Remove the new filter from packaging and remove the plastic cap.
- 4 Insert the new filter into the manifold and turn clockwise.
- 5 Once the new filter has been installed, follow instructions on the control panel. The filter life cycle will reset for approximately one year.

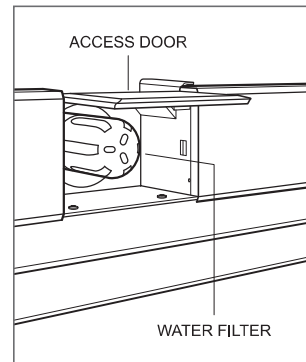

Water filter

Sub-Zero Water Filtration System Data

IMPORTANT NOTICE: Read this Performance Data Sheet carefully and compare the capabilities of this unit with your actual water treatment needs. It is recommended that, before purchasing a water treatment unit, you have your water supply tested to determine your actual water treatment needs.



System tested and certified by NSF International against NSF/ANSI Standard 42 and 53 for the reduction of substances listed below.

The concentration of the indicated substances in water entering the system was reduced to a concentration less than or equal to the permissible limit for water leaving the system, as specified in NSF/ANSI 42/53.

Contaminant Reduction*	Average Influent Concentration	NSF Specified Challenge Concentration	Average % Reduction	Product Water Concentration		NSF Reduction Requirements	NSF Test Report
				Average	Max Permissible		
Chlorine, Taste & Odor	2.0 mg/L	2.0 mg/L ± 10%	97.5%	0.05 mg/L	N/A	≥50%	J-00056501
Normal Particulate Class I, ≥0.5 to <1.0 µm	13,666,667 pts/ml	At least 10,000 particles/ml	98.9%	143,333 pts/ml	N/A	≥85%	J-00056506
Asbestos	96 MF/L	10 ⁷ to 10 ⁸ fibers/L [†]	>99%	<1 MF/L	N/A	≥99%	J-00056511
Atrazine	0.010 mg/L	0.009 mg/L ± 10%	89.3%	0.001 mg/L	0.003 mg/L	N/A	J-00056512
Benzene	0.014 mg/L	0.015 mg/L ± 10%	96.3%	0.005 mg/L	0.005 mg/L	N/A	J-00056535
Carbofuran	0.08 mg/L	0.08 mg/L ± 10%	86.6%	0.01 mg/L	0.04 mg/L	N/A	J-00056537
Cyst**	122,500 cysts/L	Min 50,000 cysts/L	99.99%	1 cyst/L	N/A	≥99.99%	J-00056513
Lead at pH 6.5	0.153 mg/L	0.15 mg/L ± 10%	99.3%	0.001 mg/L	0.010 mg/L	N/A	J-00056515
Lead at pH 8.5	0.150 mg/L	0.15 mg/L ± 10%	99.3%	0.001 mg/L	0.010 mg/L	N/A	J-00058784
Lindane	0.002 mg/L	0.002 mg/L ± 10%	97.8%	0.00004 mg/L	0.0002 mg/L	N/A	J-00058969
Mercury at pH 6.5	0.006 mg/L	0.006 mg/L ± 10%	95%	0.0003 mg/L	0.002 mg/L	N/A	J-00058785
Mercury at pH 8.5	0.006 mg/L	0.006 mg/L ± 10%	88%	0.0007 mg/L	0.002 mg/L	N/A	J-00058783
Toxaphene	0.015 mg/L	0.015 mg/L ± 10%	93.2%	0.001 mg/L	0.003 mg/L	N/A	J-00056531
Turbidity	10.8 NTU	11 ± 1 NTU	98.7%	0.153 NTU	0.5 NTU	N/A	J-00058972
P-Dichlorobenzene	0.215 mg/L	0.225 mg/L ± 10%	99.7%	0.0005 mg/L	0.075 mg/L	N/A	J-00056538

*Contaminant reduction determined by NSF testing. **Based on the use of *Cryptosporidium Parvum* oocysts. †Fibers greater than 10 µm in length.

APPLICATION GUIDELINES / WATER SUPPLY PARAMETERS

Capacity: certified for up to 750 gallons (2,839 L); up to twelve months

Service Flow: 0.78 gpm (2.95 Lpm)

Water Supply: potable water

Water Pressure: 35–120 psi (2.8–8.2 bar)

Water Temperature: 40°F–100°F (5°C–40°C)



SPECIAL NOTES

- Replacement Sub-Zero water filter cartridges can be ordered online at subzero.com/store, or contact customer care at 800-222-7820.
- It is recommended that the filter cartridge be replaced when the indicator is displayed, if there is a noticeable drop in pressure, the ice cubes become hollow, or every 12 months, whichever comes first. Replacement filter pricing information can be found at subzero.com/store.
- This filter must be installed, operated, maintained and replaced as required in order for the product to perform as advertised.
- Note that while the testing was performed under standard laboratory conditions, actual performance may vary. The contaminants or other substances removed or reduced by this water treatment system are not necessarily in your water.

Manufactured for: Sub-Zero, Inc., P.O. Box 44848, Madison, WI 53744, 800-222-7820

Ice Maker

To operate the ice maker:

- 1 To turn on the ice maker, touch  on the options screen. A single highlighted cube indicates the ice maker is turned on.  indicates the max ice feature is turned on.
- 2 To turn off the ice maker, touch  until no cubes are highlighted.

After initial start-up, discard the first few batches of ice. The ice may contain impurities from new plumbing connections.



Max ice increases ice production up to 30% for a 24-hour period. During that period, some components may run at a higher speed resulting in a unique audible tone. This is typical and will revert back after 24 hours or when the ice bin is full.

Ice may fuse together if not used regularly. To avoid, discard the ice and allow the ice maker to replenish.



Turn off the ice maker if the ice bin is removed for an extended period. The unit is equipped with a 3-minute delay after the ice bin is removed, to ensure cubes are not ejected before the ice maker is turned off or the ice bin is installed.

Night Mode

Night mode automatically reduces interior light brightness when low ambient light is detected.  appears in the upper-left corner of the control panel display when night mode is turned on.

 appears when low ambient light is detected. The interior light brightness remains reduced for three minutes, even if the ambient light changes. Touch  to increase brightness.

To turn night mode on or off:

- 1 Touch .
- 2 Touch .

Sabbath

This appliance is certified by Star-K to meet strict religious regulations in conjunction with specific instructions found on www.star-k.org.

Sabbath mode automatically turns on the interior lights at a reduced brightness. The lights stay on when the door is closed. The lights cannot be turned off in Sabbath mode.

Sabbath mode automatically turns off after 74 hours. All lighting preferences return to the previous setting when Sabbath mode is turned off.

To turn on Sabbath:

- 1 Touch .
- 2 Touch and hold  for 3 seconds.

To turn off Sabbath:

- 1 Touch and hold  for up to 10 seconds.

Water Dispenser

The 32 oz (1 L) internal water tank must fill before water flows from the dispenser. Press and hold the water dispenser paddle for up to 60 seconds until water is dispensed.

It may take several hours to chill the water to refrigerator temperature during the original fill and after a large amount of water is dispensed.

A safety feature is incorporated into the dispenser to limit continuous water flow to 60 seconds.

To dispense water:

- 1 Press a glass against the dispenser to activate the flow of water. Refer to the illustration below.
- 2 The flow of water stops when the glass is pulled away.

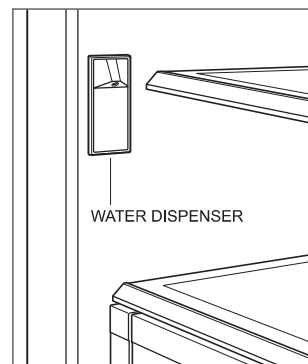

Water dispenser

Food Preservation

Food Preservation Tips—To reduce the risk of spoilage, minimize food handling. Store fruits and vegetables separately. Store meats in the original packaging; once opened, re-wrap tightly.

Ethylene Gas—Many fresh foods emit ethylene gas, a naturally-occurring compound that hastens food ripening and spoilage. Sub-Zero refrigerators come with an air purification system (based on technology developed by NASA) that scrubs the air of ethylene and odor every 20 minutes. To reduce spoilage, do not store ethylene-producing fruits and vegetables with those that are ethylene-sensitive.

e⁺ Indicates an ethylene-producing food.

e⁻ Indicates an ethylene-sensitive food.

Humidity—The optimal humidity varies for different foods. To keep food fresher longer, store foods in the areas designated in the following charts.

FOOD	ECODE	REFRIGERATOR	FREEZER
FRESH VEGETABLES			
Artichokes		1–2 weeks	Freezing fresh vegetables is not recommended
Asparagus		2–3 weeks	
Bean sprouts		7–9 days	
Beans (green or lima)	e ⁻	7–10 days	
Beets without tops		3–4 months	
Bok choy	e ⁻	3 weeks	
Broccoli	e ⁻	1–2 weeks	
Cabbage	e ⁻	3–6 weeks	
Carrots	e ⁻	1–5 months	
Cauliflower	e ⁻	3–4 weeks	
Celery		1–2 months	
Corn		5–8 days	
Cucumbers	e ⁻	10–14 days	
Eggplant*	e ⁻	1–2 weeks	
Fresh herbs	e ⁻	1–3 weeks	
Garlic*		6–7 months	
Ginger*		6 months	
Jicama*		1–2 months	
Kale	e ⁻	1–2 months	
Leeks		2 months	
Lettuce	e ⁻	2–3 weeks	
Mushrooms		1–2 weeks	
Onions		1–6 months	
Parsley	e ⁻	1–2 months	
Peas (sugar, snap, snow)	e ⁻	1–2 weeks	
Peppers (bell or chile)	e ⁻	2–3 weeks	
Potatoes*		5–10 months	
Radishes		1–2 months	
Shallots		6 months	
Spinach	e ⁻	10–14 days	
Squash (soft rind)	e ⁻	1–2 weeks	
Tamarillos		7–10 days	
Water chestnuts		2–4 months	

*Do not refrigerate.

Food Preservation

FOOD	ECODE	REFRIGERATOR	FREEZER
FRESH FRUITS			
Apples	e ⁺	1–2 months	Freezing fresh fruits is not recommended
Apricots	e ⁺	1–2 weeks	
Avocados [†]	e ⁺	2–4 weeks	
Bananas*	e ⁻	1–4 weeks	
Blueberries		10–18 days	
Cantaloupe	e ⁺	2–3 weeks	
Cherries		2–3 weeks	
Figs	e ⁺	7–10 days	
Grapefruit		6–8 weeks	
Grapes		2–3 weeks	
Honeydew melon	e ⁻	3–4 weeks	
Kiwifruit	e ⁻	4–6 weeks	
Lemons		1–6 months	
Limes		6–8 weeks	
Mangos [†]	e ⁺	2–3 weeks	
Nectarines	e ⁺	2–4 weeks	
Oranges		3–8 weeks	
Peaches		2–4 weeks	
Pears [†]	e ⁺	2–3 weeks	
Pineapple		2–4 weeks	
Plums	e ⁺	2–5 weeks	
Raspberries		3–6 days	
Strawberries		7–10 days	
Tomatoes*	e ⁺	1–3 weeks	
EGGS AND DELI			
Eggs (fresh)		3 weeks	Freezing eggs and deli is not recommended
Egg substitute (opened)		3 days	
Egg, tuna, or ham salad		3–5 days	
Lunch meat, thinly sliced		1–2 days	

*Do not refrigerate. [†]Ripen on the counter before refrigeration.

FOOD	ECODE	REFRIGERATOR	FREEZER
SOUP			
Stew with meat		3–4 days	2–3 months
Vegetable soup		3–4 days	2–3 months
MEATS, FISH, AND POULTRY			
Bacon		7 days	1 month
Beef steaks, roast		3–5 days	6–12 month
Bluefish, perch		2 days	2–3 month
Corned beef		5–7 days	1 month
Ham (whole)		7 days	1–2 months
Hamburger		1–2 days	3–4 months
Meat dishes (cooked)		3–4 days	2–3 months
Pork and veal chops		3–5 days	4–6 months
Poultry (cooked)		3–4 days	4–6 months
Poultry (raw)		1–2 days	9 months
Salmon, mackerel		4 days	5–9 months
Sausage (raw)		1–2 days	1–2 months
Shrimp		1 day	6 months
Smoked breakfast links, patties		7 days	1–2 months
DAIRY			
Butter		3 months	1 year
Cottage cheese		1–2 weeks	4 weeks
Cream cheese		2 weeks	Not recomm.
Process cheese		3–4 weeks	6–8 months
Whole or skim milk		1–2 weeks	Not recomm.
Yogurt		1 month	Not recomm.

Cleaning

STAINLESS STEEL EXTERIOR

Use a nonabrasive stainless steel cleaner and apply with a soft lint-free cloth. To bring out the natural luster, lightly wipe the surface with a water-dampened microfiber cloth followed by a dry polishing chamois. Always follow the grain of stainless steel.

INTERIOR CLEANING

To clean interior surfaces and all removable parts, wash with a mild solution of soap, water, and baking soda. Rinse and dry thoroughly. Avoid getting water on the lights and control panel.

⚠ CAUTION

Do not use vinegar, rubbing alcohol, or other alcohol-based cleaners on any interior surface.

VACATIONS

For extended vacations, turn power off at the control panel. Empty the unit and block doors open slightly to let fresh air in and keep the interior dry. The water filter should be replaced before start-up.

CONDENSER CLEANING

⚠ CAUTION

Before cleaning the condenser, turn power off at the control panel. Wear gloves to avoid injury from sharp condenser fins.

The condenser is located behind the kickplate. Clean the condenser every 6–12 months.

To clean the condenser:

- 1 Turn power off at the control panel.
- 2 Remove the kickplate by extracting the two mounting screws. Refer to the illustration below.
- 3 Use a soft bristle brush and vacuum to remove dust and lint from the condenser.

⚠ CAUTION

Failure to clean the condenser could result in temperature loss, mechanical failure, or damage.

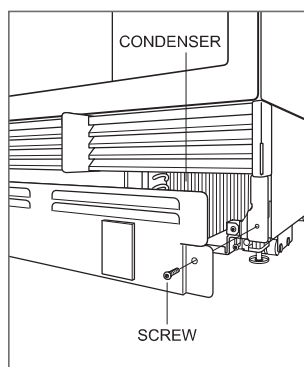

Condenser location

Troubleshooting

Before contacting Sub-Zero Factory Certified Service, visit subzero-wolf.com/assistance or use these helpful tips to prevent the need for a service visit.

UNIT OPERATION

No lights or cooling.

- 1 Verify power is on.
- 2 Verify electrical power to the unit and home circuit breaker is on.

No lights in the refrigerator or freezer.

- 1 The door/drawer may have been left ajar, which has disabled lights to eliminate excess heat. If the lights are out, close the door/drawer for one hour. If the lights are still out, contact Sub-Zero Factory Certified Service.
- 2 LED interior lighting must be replaced by Sub-Zero Factory Certified Service.

No refrigerator shelf light.

- 1 Verify the shelf is properly installed in the tracks along the back wall.
- 2 Verify nothing (a tall container or food) is preventing the shelf from engaging the tracks along the back wall.

Frost, condensation, or ice buildup inside the unit.

- 1 Verify the condenser is clean.
- 2 Verify the door/drawer is closing properly.
- 3 Verify the door/drawer has not been left ajar.
- 4 Verify the door/drawer gasket does not have rips or tears. If it does, contact Sub-Zero Factory Certified Service.
- 5 If icing is heavy, turn the unit off and use a hair dryer to melt the ice. The hair dryer should be set on low and kept moving at all times. Once the ice has melted, wipe up any water with a cloth or paper towel.

High temperatures, the unit runs excessively, or the unit is giving off too much heat.

- 1 Verify the condenser is clean.
- 2 Verify the door/drawer is closing properly.
- 3 Verify the door/drawer has not been left ajar.
- 4 Increased ambient temperatures may cause the compressors to run longer.
- 5 If the temperature display shows 38° and 0°, but is not cooling, the unit may be in Showroom Mode. Contact Sub-Zero Customer Care at 800-222-7820.

No water from the dispenser.

- 1 Wait one hour, then try the dispenser again. Contact Sub-Zero Customer Care at 800-222-7820 if unresolved.

Troubleshooting

ICE PRODUCTION

No ice.

- 1 Verify the ice cube indicator appears on the control panel display.
- 2 Verify the ice maker has been on for at least 24 hours.
- 3 Verify the freezer temperature is near 0°F.
- 4 Verify the ice bin is properly installed.
- 5 Verify the ice maker arm is in the down position.
- 6 Verify water is being supplied to the unit.
- 7 Verify the water filter has been replaced within the last 12 months and installed properly.
- 8 Verify the water filter has been removed if a reverse osmosis filtration system is being used.

Blue or green ice.

- 1 Possible copper supply line corrosion. Contact a plumber to clean or replace.

Black flecks in the cubes.

- 1 Stop use and contact Sub-Zero Factory Certified Service.

Bad taste.

- 1 Defrost the freezer and clean with soap and water.
- 2 Place coffee grounds or charcoal briquettes in the freezer to absorb odor.

Hollow cubes.

- 1 Clean the condenser. Contact Sub-Zero Factory Certified Service if unresolved.

ODOR

- 1 Clean the unit before using for the first time. This will clear any odors that may have been trapped during shipping.
- 2 Replace the air purification cartridge.
- 3 Clean the unit and shelving thoroughly.
- 4 Cover uncovered food.

Service

- Maintain the quality built into your product by contacting Sub-Zero Factory Certified Service. For the name of the nearest Sub-Zero Factory Certified Service, check the Product Support section of our website, subzero.com or call Sub-Zero Customer Care at 800-222-7820.
- When contacting service, you will need the model and serial number of your unit. Both numbers are listed on the product rating plate. Refer to pages 6–7 for rating plate location.
- For warranty purposes, you will also need the date of installation and name of your authorized Sub-Zero dealer. This information should be recorded on page 3.

Sub-Zero Residential Limited Warranty

FOR RESIDENTIAL USE

FULL TWO YEAR WARRANTY*

For two years from the date of original installation, this Sub-Zero product warranty covers all parts and labor to repair or replace, under normal residential use, any part of the product that proves to be defective in materials or workmanship. All service provided by Sub-Zero under the above warranty must be performed by Sub-Zero Factory Certified Service, unless otherwise specified by Sub-Zero, Inc. Service will be provided during normal business hours.

FULL FIVE YEAR SEALED SYSTEM WARRANTY

For five years from the date of original installation, this Sub-Zero product warranty covers all parts and labor to repair or replace, under normal residential use, these parts that prove to be defective in materials or workmanship: compressor, condenser, evaporator, drier and all connecting tubing. All service provided by Sub-Zero under the above warranty must be performed by Sub-Zero Factory Certified Service, unless otherwise specified by Sub-Zero, Inc. Service will be provided during normal business hours.

LIMITED TWELVE YEAR SEALED SYSTEM WARRANTY

For twelve years from the date of original installation, Sub-Zero will repair or replace the following parts that prove to be defective in materials or workmanship: compressor, condenser, evaporator, drier and all connecting tubing. If the owner uses Sub-Zero Factory Certified Service, the service provider will repair or replace these parts with the owner paying for all other costs, including labor. If the owner uses non-certified service, the owner must contact Sub-Zero, Inc. (using the information below) to receive repaired or replacement parts. Sub-Zero will not reimburse the owner for parts purchased from non-certified service or other sources.

TERMS APPLICABLE TO EACH WARRANTY

The warranty applies only to products installed for normal residential use. The warranty applies only to products installed in any one of the fifty states of the United States, the District of Columbia or the ten provinces of Canada. This warranty does not cover any parts or labor to correct any defect caused by negligence, accident or improper use, maintenance, installation, service or repair.

THE REMEDIES DESCRIBED ABOVE FOR EACH WARRANTY ARE THE ONLY ONES THAT SUB-ZERO, INC. WILL PROVIDE, EITHER UNDER THIS WARRANTY OR UNDER ANY WARRANTY ARISING BY OPERATION OF LAW. SUB-ZERO, INC. WILL NOT BE RESPONSIBLE FOR ANY CONSEQUENTIAL OR INCIDENTAL DAMAGES ARISING FROM THE BREACH OF THIS WARRANTY OR ANY OTHER WARRANTY, WHETHER EXPRESS, IMPLIED OR STATUTORY.

Some states do not allow the exclusion or limitation of incidental or consequential damages, so the above limitation or exclusion may not apply to you. This warranty gives you specific legal rights and you may also have other legal rights that vary from state to state.

To receive parts and/or service and the name of Sub-Zero Factory Certified Service nearest you, contact Sub-Zero, Inc., P.O. Box 44848, Madison, WI 53744; check the Product Support section of our website, subzero.com, email us at customerservice@subzero.com, or call 800-222-7820.

*Stainless steel (doors, panels, handles, product frames and interior surfaces) are covered by a limited 60-day parts and labor warranty for cosmetic defects.

*Replacement water filters and air purification cartridges are not covered by the product warranty.



Sub-Zero Outdoor Limited Warranty*

FOR RESIDENTIAL USE

FULL ONE YEAR WARRANTY**

For one year from the date of original installation, this Sub-Zero product warranty covers all parts and labor to repair or replace, under normal residential use, any part of the product that proves to be defective in materials or workmanship. All service provided by Sub-Zero under the above warranty must be performed by Sub-Zero Factory Certified Service, unless otherwise specified by Sub-Zero, Inc. Service will be provided during normal business hours.

FULL FIVE YEAR SEALED SYSTEM WARRANTY

For five years from the date of original installation, this Sub-Zero product warranty covers all parts and labor to repair or replace, under normal residential use, these parts that prove to be defective in materials or workmanship: compressor, condenser, evaporator, drier and all connecting tubing. All service provided by Sub-Zero under the above warranty must be performed by Sub-Zero Factory Certified Service, unless otherwise specified by Sub-Zero, Inc. Service will be provided during normal business hours.

TERMS APPLICABLE TO EACH WARRANTY

The warranty applies only to products installed for normal residential use. The warranty applies only to products installed in any one of the fifty states of the United States, the District of Columbia or the ten provinces of Canada. This warranty does not cover any parts or labor to correct any defect caused by negligence, accident or improper use, maintenance, installation, service or repair.

THE REMEDIES DESCRIBED ABOVE FOR EACH WARRANTY ARE THE ONLY ONES THAT SUB-ZERO, INC. WILL PROVIDE, EITHER UNDER THIS WARRANTY OR UNDER ANY WARRANTY ARISING BY OPERATION OF LAW. SUB-ZERO, INC. WILL NOT BE RESPONSIBLE FOR ANY CONSEQUENTIAL OR INCIDENTAL DAMAGES ARISING FROM THE BREACH OF THIS WARRANTY OR ANY OTHER WARRANTY, WHETHER EXPRESS, IMPLIED OR STATUTORY.

Some states do not allow the exclusion or limitation of incidental or consequential damages, so the above limitation or exclusion may not apply to you. This warranty gives you specific legal rights and you may also have other legal rights that vary from state to state.

To receive parts and/or service and the name of Sub-Zero Factory Certified Service nearest you, contact Sub-Zero, Inc., P.O. Box 44848, Madison, WI 53744; check the Product Support section of our website, subzero.com, email us at customerservice@subzero.com, or call 800-222-7820.

*Product must be approved for outdoor use, designated by model and serial number.

**Stainless steel (doors, panels, handles, product frames and interior surfaces) are covered by a limited 60-day parts and labor warranty for cosmetic defects.

**Replacement water filters are not covered by the product warranty.

